

Copyright

Fujitsu Limited has made every effort to ensure the accuracy and completeness of this document. However, as ongoing development efforts are continually improving the capabilities of our products, we cannot guarantee the accuracy of the contents of this document. We disclaim liability for errors, omissions, or future changes.

LifeBook is a trademark of Fujitsu Limited.

Microsoft, Windows, MS, MS-DOS, and Windows NT are registered trademarks of the Microsoft Corporation of the United States in the United States and other countries.

Intel is a registered trademark of the Intel Corporation of the United States.

Celeron is a trademark of the Intel Corporation of the United States.

NeoMagic MagicMedia 256AV and NeoMagic MagicMedia 256AV+AC97 Driver (WDM) are trademarks of NeoMagic™ Corporation.

Puma Technology, Intellisync is a trademark of Puma Technology Corporation of the United States.

Phoenix is a registered trademark of Phoenix Technologies Corporation of the United States.

K56flex is a trademark of Rockwell International Corporation and Lucent Technologies Corporation.

Magic Packet is a registered trademark of Advanced Micro Devices, Inc.

Other product names are trademarks or registered trademarks of their respective companies.

Other products are copyrighted by their companies.

Copyright© 1981-2000 Microsoft Corporation, All rights reserved.

Copyright© 2000 Phoenix Technologies, Ltd., All rights reserved.

All other products are trademarks or registered trademarks of their respective companies.

Explanations of the adjustments for the track pad cursor control are taken in part from the ALPS GlidePoint Driver User's Guide, copyright by LCS/Telegraphics in 1996.

© Copyright 2000 Fujitsu Limited. All rights reserved. No part of this publication may be copied, reproduced, or translated, without the prior written consent of Fujitsu Limited. No part of this publication may be stored or transmitted in any electronic form without the written consent of Fujitsu Limited.



DECLARATION OF CONFORMITY according to FCC Part 15

Responsible Party Name : FPCA
Address : Fujitsu PC (Asia) Pte Ltd
200 Pandan Loop
#05-03, Pantech 21
The Computer Centre
Singapore 128388
Telephone : 65-776 0688
Declares that product: Model : LifeBook C6544
Complies with Part 15
of the FCC Rules.

This device complies with Part 15 of the FCC Rules. Operations are subject to the following two conditions:
(1) This device must not be allowed to cause harmful interference, (2) This device must accept any interference received, including interference that may cause undesired operation.

IMPORTANT SAFETY INSTRUCTIONS

1. Read these instructions carefully. Save these instructions for future reference.
2. Follow all warnings and instructions marked on the product.
3. Unplug this product from the wall outlet before cleaning. Do not use liquid cleaners or aerosol cleaners. Use a damp cloth for cleaning.
4. Do not use this product near water.
5. Do not place this product on an unstable cart, stand, or table. The product may fall, causing serious damage to the product.
6. Slots and openings in the cabinet and the back or bottom are provided for ventilation; to ensure reliable operation of the product and to protect it from overheating, these openings must not be blocked or covered. The openings should never be blocked by placing the product on a bed, sofa, rug, or other similar surface. This product should never be placed near or over a radiator or heat register, or in a built-in installation unless proper ventilation is provided.
7. This product should be operated from the type of power indicated on the marking label. If you are not sure of the type of power available, consult your dealer or local power company.
8. This product is equipped with a 3-wire grounding-type plug, a plug having a third (grounding) pin. This will only plug into a grounding-type power outlet. This is a safety feature. If you are unable to insert the plug into the outlet, contact your electrician to replace your obsolete outlet. Do not defeat the purpose of the grounding-type plug.
9. Do not allow anything to rest on the power cord. Do not locate this product where persons will walk on the cord.
10. If an extension cord is used with this product, make sure that the total ampere rating of the equipment plugged into the extension cord does not exceed the extension cord ampere rating. Also, make sure that the total rating of all products plugged into the wall outlet does not exceed 15 amperes.
11. Never push objects of any kind into this product through cabinet slots as they may touch dangerous voltage points that could result in a fire or electric shock. Never spill liquid of any kind on the product.
12. Do not attempt to service this product yourself, as opening or removing covers may expose you to dangerous voltage points or other risks. Refer all servicing to qualified service personnel.
13. Unplug this product from the wall outlet and refer servicing to qualified service personnel under the following conditions:
 - a. When the power cord or plug is damaged or frayed.
 - b. If liquid has been spilled into the product.
 - c. If the product has been exposed to rain or water.
 - d. If the product does not operate normally when the operating instructions are followed. Adjust only those controls that are covered by the operating instructions since improper adjustment of other controls may result in damage and will often require extensive work by a qualified technician to restore the product to normal condition.
 - e. If the product has been dropped or the cabinet has been damaged.
 - f. If the product exhibits a distinct change in performance, indicating a need for service.
14. **CAUTION. When replacing the battery, be sure to install it with the polarities in the correct position. There is a danger of explosion if the battery is replaced with an incorrect type or is mistreated. Do not recharge, disassemble or dispose of in fire. Replace only with the same or equivalent type recommended by the manufacturer. Dispose of the used battery according to the manufacturer's instructions.**
15. Use only the proper type of power supply cord set (provided in your accessories box) for this unit. It should be a detachable type: UL listed/CSA certified, BS1363,ASTA,SS145 certified, rated 10A 250V minimum, VDE approved or its equivalent. Maximum length is 15 feet (4.6 meters).

AUSTRALIAN WARNINGS

WARNING

FOR SAFETY REASONS, ONLY CONNECT EQUIPMENT WITH A TELECOMMUNICATIONS COMPLIANCE LABEL. THIS INCLUDES CUSTOMER EQUIPMENT PREVIOUSLY LABELLED PERMITTED OR CERTIFIED.

Connection of Non Certified/Approved peripherals may result in the equipment operating outside the Australian EMI Standards.

Modems connected to the Australian telecommunications network must be operated in accordance with the Labelling Notice. This modem has been specifically configured to ensure compliance with the ACA Standards. Do not adjust your modem or software outside the values indicated below. To do so would result in your modem being operated in a non-compliant manner.

Call Attempts/Retries:

Applications software shall be configured so that no more than 3 attempts are made to establish a connection to a given number (Note: if the modem can detect service tones, up to 10 attempts can be made). If the call sequence is unsuccessful, there shall be a delay of at least 30 minutes before attempting to call the number again.

Failure to set the modem, and any application software used with the modem, to the values shown above will result in the modem being operated in a non-compliant manner. Consequently, this would be in violation of the Labelling Notice for this equipment, and the Telecommunications Act 1997 prescribes penalties for the connection of non-compliant equipment.

NEW ZEALAND WARNINGS

The grant of a Telepermit for any item of terminal equipment indicates only that Telecom has accepted that the item complies with minimum conditions for connection to its network. It indicates no endorsement of the product by Telecom, nor does it provide any sort of warranty. Above all, it provides no assurance that any item will work correctly in all respects with another item of Telepermitted equipment of a different make or model, nor does it imply that any product is compatible with all of Telecom's network services.

This equipment is not capable under all operating conditions of correct operation at the higher speeds for which it is designed. 56 KBPS connections are likely to be restricted to lower bit rates when connected to some PSTN implementations. Telecom will accept no responsibility should difficulties arise in such circumstances.

Immediately disconnect this equipment should it become physically damaged, and arrange for its disposal or repair.

This equipment shall not be used in any manner, which could constitute a nuisance to other Telecom customers.

This equipment shall not be set to make automatic calls to the Telecom "111" Emergency Service. This device is equipped with pulse dialling while the New Zealand standard is DTMF tone dialling. There is no guarantee that Telecom lines will always continue to support pulse dialling. It is strongly recommended that pulse dialling is not used.

Some parameters required for compliance with Telecom's Telepermit requirements are dependent on the equipment (PC) associated with this device. The associated equipment shall be set to operate within the following limits for compliance with Telecom's Specifications:

For repeat calls to the same number.

There shall be no more than 10 call attempts to the same number within any 30 minute period for any single manual call initiation, and

The equipment shall go on-hook for a period of not less than 30 seconds between the end of one attempt and the beginning of the next attempt.

For Automatic calls to different numbers.

The equipment shall go on-hook for a period of not less than 5 seconds between the end of one attempt and the beginning of the next attempt.

For Automatically answered Incoming Calls

Incoming calls shall be answered between 3 and 30 seconds from the start of the ringing.

For correct operation, the total of the RNs of all devices connected to a single line at anytime should not exceed 5. The RN of this Equipment is 0.5.

WARNING

Connection of Non Certified/Approved peripherals may result in the equipment operating outside the New Zealand EMI Standards.

Note: Modem setting in Windows 98

The default modem setting in Windows 98 operating system is United States of America. If you are residing in Australia or New Zealand, please choose the appropriate country where you are located.

Dial type must be set to Tone Dialing if you are either in Australia or New Zealand.

Please see below instruction for quick modem setup.

A. If you are located in Australia

1. Go to Control panel, select modem icon.
2. Choose Australia in "What country/region are you in now?"
3. Select Phone system as "Tone Dialing"
4. Close

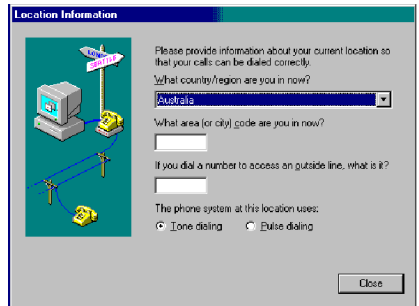

B. If you are located in New Zealand

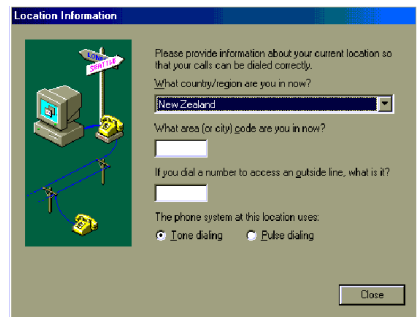

1. Go to Control panel, select modem icon.
2. Choose New Zealand in "What country/region are you in now?"
3. Select Phone system as "Tone Dialing"
4. Close





NOTATION IN THIS DOCUMENT

● Warnings

This manual uses a variety of icons as visual marks so that you can use this computer safely and correctly and avoid damage and danger to yourself and to others. These icons and their meanings are as follows. Please learn these icons before reading this manual. Learning these icons will be useful for understanding this manual.

| Icon | Meaning |
|--|---|
|  WARNING | Incorrect handling ignoring this warning can cause a dangerous situation that could result in death or severe injury. |
|  CAUTION | Incorrect handling ignoring this warning can cause a dangerous situation that could result in moderate or minor injury or could result in equipment damage. |

The symbols below are used together with the icons above to indicate what type of danger or damage is involved.

| symbols | Meaning |
|---|---|
|  | The symbol Δ indicates a warning or caution. The symbol Δ indicates the concrete nature of the warning. (The example on the left is a caution for electric shock.) |
|  | The circle and slash indicates prohibited behavior. The symbol inside the circle indicates the concrete nature of the prohibition. (The example on the left indicates that disassembly is prohibited.) |
|  | The ● indicates instructions that must be followed. The symbol inside the circle indicates the concrete nature of those instructions. (The example on the left tells you to unplug the power plug from the socket.) |

● Key notation and operation methods

Explanations of key operations do not show all the characters on the keyboard. Instead they indicate just the keys necessary to the explanation as follows.

Examples: **[Ctrl]** key, **[Enter]** key, [→] key

When multiple keys are to be pressed at the same time, this is indicated by connecting them with **[+]**.

Examples: **[Ctrl] + [F3]** keys; **[Shift] + [↑]** key

● Screen examples

The screens shown in this manual are examples. Please understand that the file names and screens you use may be different.

● Notation in text

Here is what symbols in text mean.

| Symbol | Meaning |
|---|--|
| Critical Points | Critical Point Indicates a point necessary for correctly operating the hardware or software. |
|  Column | Column Gives the meaning and brief explanation of a term. |
| → | Indicates the page to see elsewhere in this manual. |

● Command input (key input)

Within the text of this manual, command input (giving commands to the computer by pressing keys) is indicated as follows.

Example: `dir c:`



In the position indicated in the example above by the ↑, the space left between the characters indicates that a space needs to be left in the entry by pressing the space bar (the long key with nothing written on it at the center of the front of the keyboard). Commands are written in this manual as lowercase latin letters, but uppercase letters may be used.

● Product names

The following product names are abbreviated as follows in this manual.

“Microsoft® Windows® 2000 operating system” is written as “Windows 2000”.

“Microsoft® Windows® 98 operating system” is written as “Windows 98”.

“Microsoft® MS-DOS® operating system Version 6.2/V” is written as “MS-DOS”.

“Microsoft® Windows® operating system Version 3.1” is written as “Windows 3.1”.

“Microsoft® Windows NT® Workstation operating system Version 4.0” is written as “Windows NT 4.0”.

“Microsoft® Windows NT® Workstation operating system Version 3.51” is written as “Windows NT 3.51”.

“Windows NT 4.0” and “Windows NT 3.51” are both written as Windows NT.

“LifeBook” is written as “this computer” or “the computer main unit”.

Configuration of this Manual

SECTION 1

This section explains basic operations and basic items for using this computer, including the names of the parts and their functions, flat point operation methods, floppy disk unit handling, and battery operation.

SECTION 1

SECTION 2

This section explains installation of options for this computer.

SECTION 2

SECTION 3

This section explains the BIOS setup program, which is necessary for setting the date and time and power conservation mode. This section also explains how to set the password for protecting data in this computer.

SECTION 3

SECTION 4

This section explains what to do when trouble occurs with this computer and when messages are displayed. Read this section as the necessity arises.

SECTION 4

CONTENTS

SECTION 1

| | |
|--|-----------|
| 1. Names of the Parts and their Functions | 2 |
| Front | 2 |
| Right Side | 5 |
| Left Side | 7 |
| Rear/Bottom | 8 |
| One-touch Buttons/CoolView | 10 |
| 2. Keyboard | 14 |
| Keyboard | 14 |
| Numeric Keypad Mode | 14 |
| Names of the Main Keys and their Functions | 15 |
| 3. Turning on the Power | 18 |
| Turning on the power | 18 |
| 4. Turning off the Power | 20 |
| Turning Off the Power | 20 |
| 5. Suspend/Resume Function | 22 |
| What Is the Suspend/Resume Function? | 22 |
| Precautions for Suspending | 22 |
| Suspending | 23 |
| Using the Resume Function | 25 |
| 6. Battery | 26 |
| Battery Charging | 26 |
| Battery Operation | 27 |
| Checking the Remaining Battery Charge | 28 |
| Low Battery State | 29 |
| Replacing the Battery Pack | 30 |
| Bridge Battery | 32 |
| Precautions for Battery Pack | 33 |
| 7. Floppy Disk Drive | 34 |
| Loading/Ejecting a Floppy Disk | 34 |
| What is a Floppy Disk? | 35 |
| Precautions on Handling | 36 |
| 8. CD-ROM Drive | 37 |
| CD-ROMs | 37 |
| Loading/Ejecting a CD-ROM | 38 |
| 9. Internal Fax Modem | 40 |
| What is a Fax Modem? | 40 |
| Connection | 40 |
| Modem Warnings | 41 |

SECTION 1

| | |
|--|-----------|
| 10. SPDIF Features | 42 |
| How to use the SPDIF Output Connector? | 42 |

SECTION 2

| | |
|--|-----------|
| 1. Options | 44 |
| Options | 44 |
| 2. PC Cards | 46 |
| Precautions for PC Cards | 46 |
| Installing PC Cards | 47 |
| Removing PC Cards | 48 |
| 3. Expansion RAM Modules | 49 |
| 4. Mouse | 52 |
| Connecting the Mouse | 52 |
| Using the Mouse | 52 |
| 5. Numeric Keypad | 54 |
| Connecting a Numeric Keypad | 54 |
| 6. Printer | 55 |
| Connecting a Printer | 55 |
| 7. CRT Monitor / TV | 57 |
| Connecting an External CRT Monitor | 57 |
| Connecting to a TV | 58 |
| 8. Wireless Mouse | 59 |

SECTION 3

| | |
|--|-----------|
| 1. BIOS setup | 68 |
| 2. POST Diagnostic Screen | 93 |

SECTION 4

| | |
|--------------------------------------|------------|
| 1. When This Happens | 96 |
| 2. Care and Maintenance | 101 |
| 3. Glossary | 106 |

SECTION

1

This section explains basic operations and basic items for using this computer, including the names of the parts and their functions, Flat point operation methods, floppy disk unit handling, and battery operation.

1. Names of the Parts and their Functions

Front

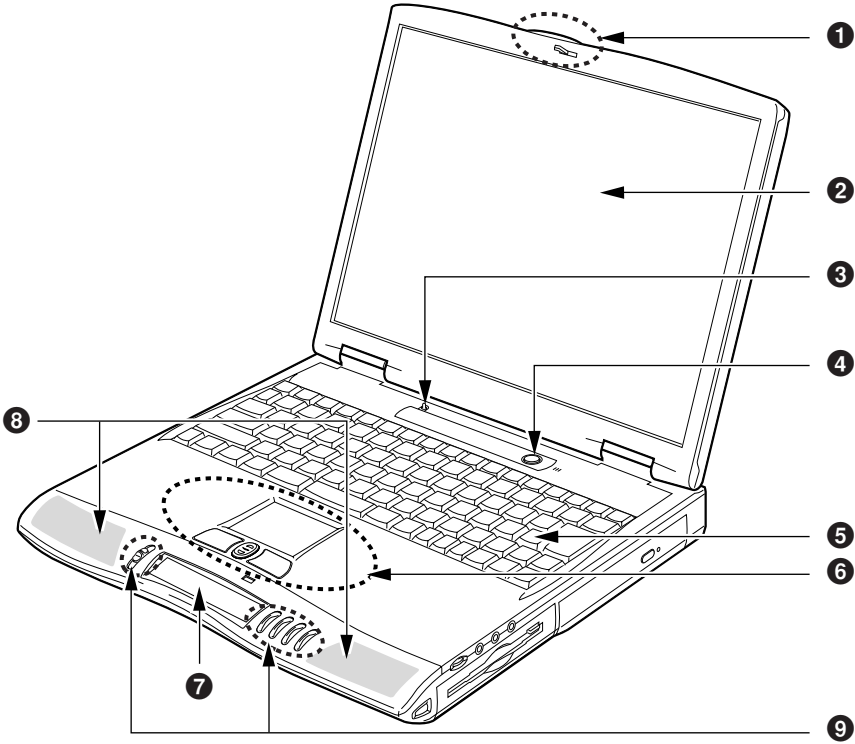

1 Display Panel Latch

Locks the LCD panel so that it will not inadvertently be opened. To unlock and open the LCD panel, slide this latch to the right.

2 Liquid Crystal Display (LCD) Panel

Shows a screenful of data from the computer main unit.

Critical Points**About the characteristics of the LCD panel**

Note that the following symptoms reflect the characteristics of the LCD and imply no hardware problem:

- The TFT color liquid crystal display of this personal computer is made up of more than 441 million pixels (dots) (at 1,400x1,050 dots resolution) or 235 million pixels (at 1,024x768 dots resolution) which are fabricated using an advanced technology. Consequently, the display may have some pixels that will not turn on or that always stay on. Such pixels do not imply any display failure and should not be regarded as defective.
- The liquid crystal displays used in the personal computers of this model may have different hues for reasons associated with the fabrication processes. Your liquid crystal display may characteristically bear some color shadings due to changes in the ambient temperature.

3 Closed Cover Switch

Used to place the personal computer into the Standby (Suspend) or Resume mode or to turn off the backlight of the LCD when you open or close the LCD.

4 SUS/RES Button

Used to turn on the personal computer and to place it into the standby or resume mode.

5 Keyboard

Used to type in letters and give commands to the personal computer.

6 Flat Point

Used to manipulate the mouse pointer. Pressing the scroll button at the center causes the screen to scroll up or down.

Critical Points

- The flat point may malfunction due to condensations or moisture formed on its surface. The mouse pointer may not function normally if you manipulate it with a wet or sweaty hand or if the surface of the flat point is dirty. In such a case, turn off the personal computer and clean it with a soft cloth moistened with mild neutral detergent.
- Depending on the application you are using, you may not be able to scroll the screen using the scroll button.

7 CoolView

Shows the status of messages from the personal computer, notification on incoming E-mail with messages and blinking backlight.

8 Speakers

Produce the sound of the personal computer.

9 One-touch Button

Pressed to activate an application or to receive incoming e-mail. This button is also used to play back an audio CD.

Critical Points

- Do not set the MAIN switch to OFF when using the one-touch button.

Right Side

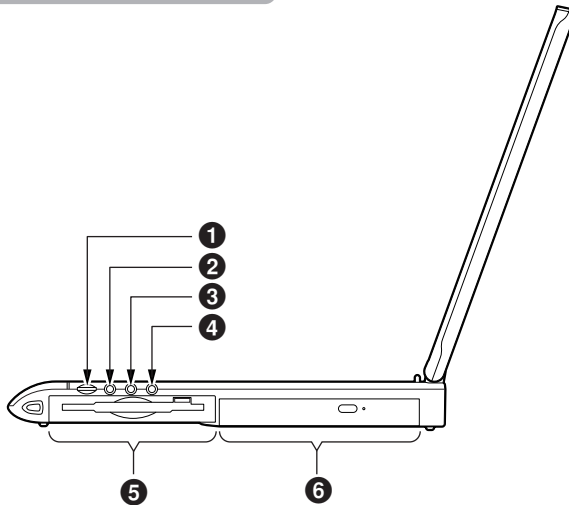
**Caution**

Failure of an attached device or a hideous or deafening sound may cause harmful effects on your ears. Set the volume control on your personal computer's main unit to its minimum before plugging a cable into the HEADPHONE, LINE IN, or MICRO IN jack.

1 Volume Control

Adjusts the volume of the speakers. Turning the volume control anti clockwise raises the volume and turning it clockwise reduces the volume. If you can hear no sound when you adjust the volume control, keep pressing [F3] while holding down [Fn] until you hear a beep. Also make sure that the volume setting in the [Volume Control] dialog box is not set to "Mute." You can set the balance and volume of the sound input/output in the [Volume Control] dialog box. If the volume is found inadequate even when the volume is set to its maximum level, set the volume control in the [Volume Control] dialog box.

2 HEADPHONE Jack

Connects to a commercially available headphone (3.5 mm mini-plug). Some models of headphones may not fit in this jack, however. Make a check before purchasing a headphone.

**Caution**

Take care not to listen over your headphone at too high a volume. Listening over a headphone at a deafening sound level for an extended period may cause harmful effects on your ears.



Do not turn on or off your personal computer with a headphone on. A loud pop might cause harmful effects on your ears.

3 Stereo Line-in Jack and Optical Digital Audio Output Terminal

The stereo line-in jack allows you to connect an external audio source. This terminal also serves as an Optical Digital Audio Output Terminal.

The Optical Digital Audio Output Terminal allows you to download digital audio onto Sony & Philips Mini-disc player's SPDIF (Sony Philips Digital Interface) format.

Important note

- Since light is emitted from the optical digital audio output terminal, do not peek into the terminal when plugging in a cable.
- The frequency of the digital audio generated from the optical digital audio output terminal is fixed at 48 kHz. You can record no sound on any digital device (e.g., MD player) that has no sampling rate converter built in. For details, refer to the instruction manual attached to the digital device.
- The sound that is recorded on a digital device (e.g., MD player) connected to the optical digital audio output terminal cannot be output in digital form. All output from the optical digital audio output terminal is subject to copy protection.

4 MIC IN Jack

Connects to a commercially available microphone for recording (monaural) (compatible with a 3.5 mm mini-plug). Some models of commercially available microphones (e.g., movingcoil microphones) are incompatible with this jack. Make a check before purchasing a microphone.

5 Floppy Disk Drive

Used to read and write floppy disk data.

6 CD/DVD Drive

Used to read in CD-ROM data and play back audio CD.

A CD-R/RW drive can rewrite CD-R/RW data and a DVD-ROM drive can play back DVD video or read in DVD-ROM data.

Left Side

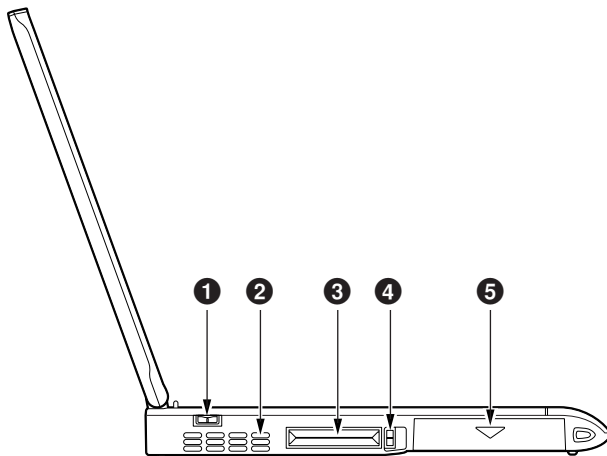
**1 MAIN Switch**

The main power switch of the personal computer.

2 Cooling Fan

Used to vent hot air out of the personal computer interior. The fan starts rotating when the temperature inside the personal computer increases to a certain level.

**Caution**

Do not block the vent of the cooling fan. The heat would stagnate inside the personal computer, causing machine failures.

3 PC Card Slots

Used to house optional PC cards. The lower slot is designated as slot 1 and the upper slot as slot 2.

Critical Points

- In some optional OSes, "slot 1" is referred to as "slot 0" and "slot 2" as "slot 1."

4 PC Card Eject Button

Pressed to eject a PC card.

5 Built-in Battery Pack

Houses a built-in battery pack.

Rear/Bottom

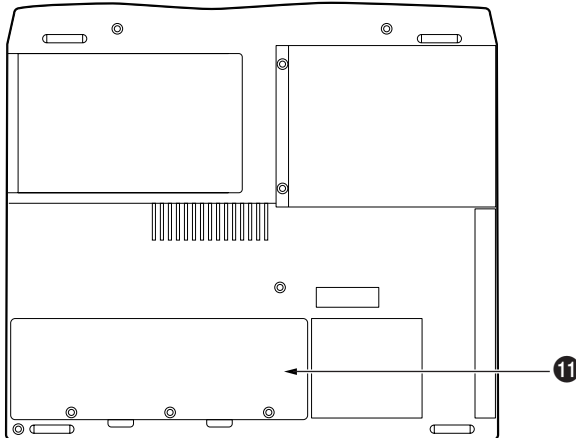
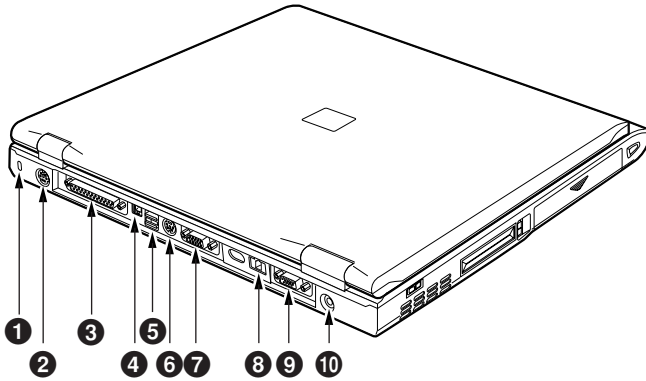

1 Theft Prevention Lock Slot

Can accept a commercially available theft prevention cable.

Critical Points

- The theft prevention lock is compatible with the Kengington's microsaver security system.

2 Extended Keyboard/Mouse Connector

Connects to an optional keyboard or mouse.

3 Parallel Connector

Connects to an optional printer.

4 IEEE 1394 (DV) Terminal

Used to connect between the personal computer and a peripheral, such as digital video camera (DV), with a DV cable.

5 USB Connector

Connects to a USB compatible peripheral such as a USB mouse.

6 S Video Output Terminal

Used to transmit the S video signal.

7 External Display Connector

Connects to an external display such as an optional CRT display.

8 Modular Connector

Used to connect between the personal computer and a telephone line with the attached modular cable for communication with a BBS or the Internet.

9 Serial Connector

Connects to an RS-232C compatible device.

10 DC-IN Connector

Accepts the attached AC adapter.

Important note

- When cabling a peripheral device, check the orientation of its cable connector and plug it straight into the mating connector.

11 Expansion RAM Module Slot

Used to house an optional memory module.

One-touch Buttons/CoolView

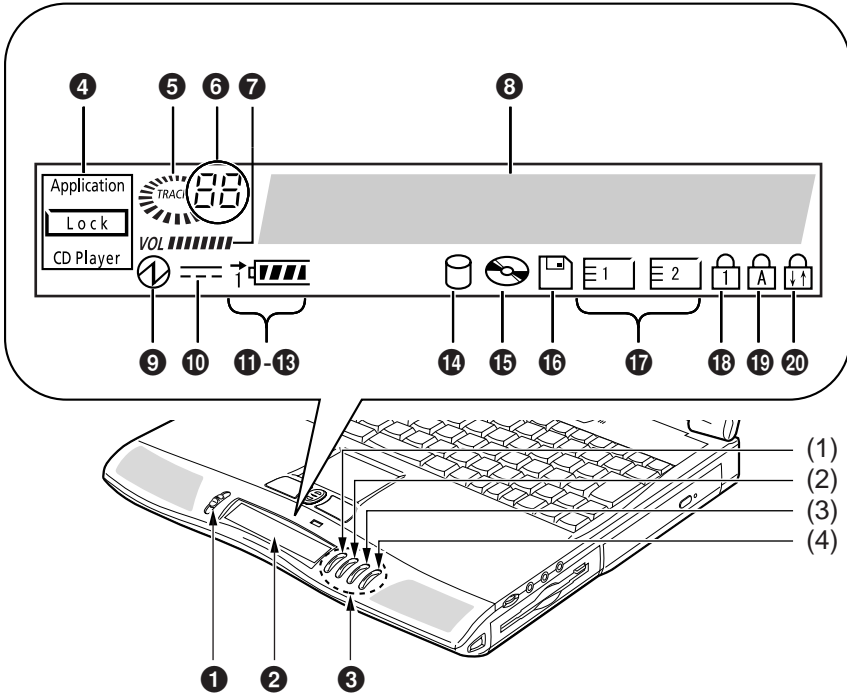

1 Mode Switch







The position of the Mode Switch determines the functionality of the one-touch buttons. Set the Mode Switch at the center when you are not using one-touch button.

2 CoolView

Shows the status of and messages from the personal computer.

3 One-touch Buttons



The one-touch buttons are used to start applications, control audio CD, with the display panel closed. The functionality of the one-touch buttons is determined as summarized in the table below depending on the position of the Mode switch.

| Mode Switch Position | Button | | | |
|--|---|---|--|---|
| | (1) | (2) | (3) | (4) |
| Application (Upper)  | Button A | Button B | Internet button | E-mail button |
| Lock (Center)  | All buttons are disabled. Prevents a button from being pressed inadvertently. | | | |
| CD Player (Lower)  | Stop/Eject  | Play/Pause  | Fast Backward  | Fast Forward  |

While Windows 98 is active, the CD Player one-touch buttons are interlocked with the actions of the CD player buttons, except the Eject button.

While Windows 98 is not active, the CD Player one-touch buttons are interlocked with action of the CD player buttons.

Critical Points

- For instructions to change an application assigned to a one-touch button, see the Lifebook Application Panel Software installed in your computer
- If you changed settings so that the EJECT function is activated when the  button is pressed, do not press the  button while you are using a CD. An error window might appear.

4 Mode Display

As you switch the Mode switch for the one-touch buttons, the current mode is shown enclosed in a box.

Critical Points

- The mode is not shown if the MAIN switch is set to OFF.

5 CD Mark

The  mark revolves when you play back an audio CD when the personal computer is in the standby mode or at the end of Windows.

6 CD Track Display

The number of the track on playback is shown when an audio CD is being played back using the one-touch buttons for the CD player.

• Numerals

Indicate the track number of the track on playback. The track number of the first track is indicated when the CD player is in the stopped state.

• — —

Appears when no audio CD is set or when an audio CD is being read.

• SP

Appears when the personal computer is in the power save mode. Pressing the  button restores the CD player in the state in which you can manipulate the audio CD.

7 Volume Level Display

Indicates the volume you set up with the volume control in 8 increments.

Critical Points

- There may be times when the volume setting you made with the volume control do not agree with the volume level display.

8 Message Display Area

Shows various messages depending on the situations such as when the personal computer is started and when e-mail arrives.

9 SUS/RES ()

Stays on when your personal computer is running and flashes when it is in the standby mode.

10 AC Adapter ()

Stays on when power is being supplied from the AC adapter.

11 Battery (1.)

Stays on when a battery is installed.

12 Battery Charging ()

Stays on when the battery is being charged. Flashes when the battery is not being charged because it is too hot or cold.

13 Battery Level ()

Indicates the charge level of the battery.

14 Hard Drive Access ()

Stays on when the internal hard disk drive is being accessed.

15 CD Access ()

Stays on when the CD is being accessed.

16 Floppy Disk Drive Access ()

Stays on when the floppy disk is being accessed.

17 PC Card Access ( )

Stays on when the corresponding PC card is being accessed.

18 Num Lock ()

Stays on when the keyboard is in the numeric lock mode. Press [Num Lk] to turn on and off the numeric lock mode.



19 Caps Lock ()

Lit when the personal computer is placed into the Caps Lock mode (letters are entered all in uppercase). Press [Caps Lock] while holding down [Shift] to turn on and off the Caps Lock mode.

20 Scroll Lock ()

Lit when the personal computer is set up so that the screen will not scroll at all (scroll lock). Press [Screen Lk] while holding down [Fn] to turn on and off the scroll lock mode. The operation of the personal computer depends on the application that is being executed.

Critical Points

- Data on the hard disk drive or floppy disk drive may be corrupted if you turn off the MAIN switch or manipulate the SUS/RES switch when the Hard Disk Drive Access or Floppy Disk Drive Access indicator is on.
- While the MAIN switch is set to OFF, all CoolView illuminators are off except when the battery is being charged.
- Under some optional OSEs, PC Card Access display “Slot 1” may appear as “Slot 0” and “Slot 2” as “Slot 1.”
- Checks for the presence or absence of a CD are made periodically if the automatic CD insertion feature is enabled. Accordingly, the CD Access illuminator on the CoolView lights periodically. Follow the steps shown below to disable the automatic CD insertion feature.
 - 1 Click [Start], [Settings], and [Control Panel] in that order.
 - 2 Click [] (System).
 - 3 Click the [Device Manager] tab.
 - 4 Click [] to the left of [CD-ROM].
A CD-ROM device will appear.
 - 5 Click the CD-ROM device and click [Properties].
The [CD-ROM Device Properties] dialog will box appear.
 - 6 Click the [Settings] tab.
 - 7 Click and uncheck [Automatically notify insertion] under “Options.”
 - 8 Click [OK].
 - 9 Click [OK] or [Close] in the [System Properties] dialog box.
You will be brought back to the [Control Panel] window.
 - 10 Restart the personal computer.

To re-enable automatic CD insertion, click and check [Automatically notify insertion] in Step 7.

2. Keyboard

Keyboard

The keyboard is the device for giving instructions to the computer, inputting data, and executing. The keys can be divided into two types.

- : Control keys
- : Character keys

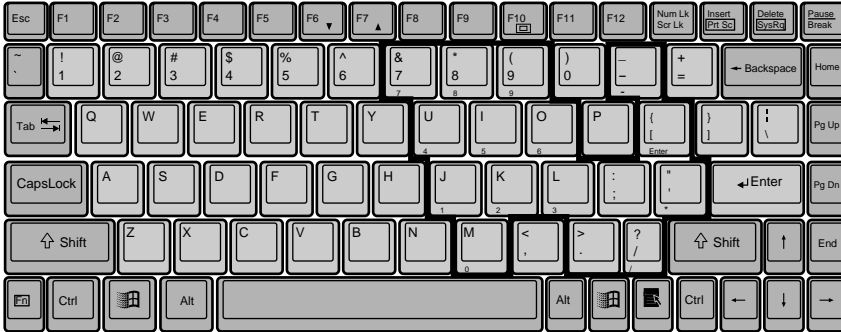

Numeric Keypad Mode

The mode in which some of the character keys are used as numeric keys (with a key layout that makes numeric input easier) instead of their normal functions is called numeric keypad mode. The keyboard is switched to numeric keypad mode with **[Num Lk]**. (In numeric keypad mode,  is displayed on the status indicator LCD.) The keys surrounded by thick lines in the diagram above become the numeric keypad. The numbers input with these keys are printed in pink on the front of each key.

Critical Point

- When the separately sold numeric keypad is connected, if you press **[Num Lk]** to put the computer into numeric keypad mode, the keys on the external numeric keypad are enabled, but the numeric keypad section on the keyboard is disabled.

Names of the Main Keys and their Functions

[Esc] (escape) key

The usage is determined by the application software. It is often used to return to the previous operation.

[F1]-[F12] (function) keys

The usage depends on the application software.

[Fn] key

A key unique to this computer; it has the following functions.

- [Fn] + [F3]** This switches ON/OFF of the speaker.
When a pip sounds with this operation, the speaker is on. When nothing sounds, the speaker is turned off.
- [Fn] + [F5]** This selects whether or not to use the entire LCD display panel for display in text mode.
- [Fn] + [F6]** Turns down the backlight of the LCD.
- [Fn] + [F7]** Turns up the backlight of the LCD.

Critical Point

- Luminance of the backlight of the LCD can be turned up (with **[Fn] + [F7]** keys) or turned down (with **[Fn] + [F6]** keys) in three degrees.

- [Fn] + [F10]** Rotates among the three display options: LCD only, CRT only, both LCD and CRT.

[Space] key

Inputs a single space character.
(This is the long key with nothing written on it at the center of the front of the keyboard.)

[↑] [↓] [←] [→] (cursor) keys

Move the cursor.

[Enter] key

Also called the return key or the line feed key. This key inputs line feeds and executes command.

[Ctrl] (control) key

Used in combination with other keys; its functions depend on the application software.

[Shift] key

Used in combination with other keys.

[Alt] key

Used in combination with other keys; its functions depend on the application software.

[Caps Lock] key

To lock the keyboard into caps mode, press this key together with the Shift key. Pressing this key again ends caps mode.

[Num Lk] (numerical lock) key

Press this key to put the computer into numeric keypad mode.

[Scr Lk] (scroll lock) key

Its functions depend on the application software.

[Print Screen] key

Press this key to make a hard copy of the screen.

[Pause] key

Press this key to pause the screen display.

[Break] key

Its functions depend on the application software.

[Insert] key

Press this key to insert a new character between characters. The new characters are entered at the cursor position.

[Delete] key

Press this key to delete a character. Pressing the Delete key and the **[Ctrl]** and **[Alt]** keys at the same time resets this computer.

[Home] key

Press this key to move the cursor directly to the head of the row or the head of the document.

[End] key

Press this key to move the cursor directly to the end of the row or the end of the document.

[Page Up] key

Press this key to switch to the previous screen.

[Page Down] key

Press this key to switch to the next screen.

[Back Space] key

Press this key to delete the character to the left of the cursor position.

[Sys Rq] (system request) key

When this key is supported by the application software, this key is used for such functions as resetting the keyboard. Press this key together with the Alt key.

[] (Windows) key

Press this key to display the Start menu.

[] (Application) key

Press this key to display the shortcut menu for the selected item. This key has the same role as the mouse right click.

3. Turning on the Power

Turning on the power

This item explains the normal way to turn the computer main unit power on and off.

1 Connect the AC adaptor.

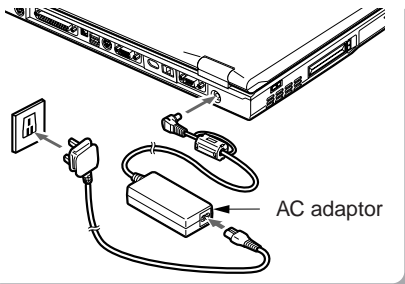

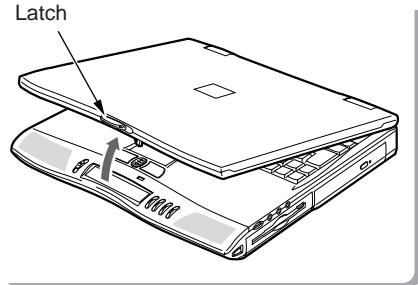

2 Open the LCD display panel.

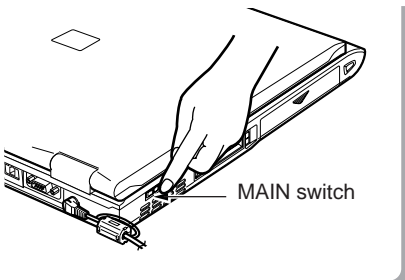

Pull the latch to release the lock, then lift the display panel with your hand.

3 Switch on the main switch of the computer main unit.



Power is supplied from the AC adaptor or the battery, the power comes on, and the POST starts. Also, the  etc. on the status indicator LCD are displayed.

Critical Point

- Do not carry this computer around or subject it to shock or vibration with the power on. These can result in breakdown.

**Column**

POST is the abbreviation for POWER ON SELF TEST, which is a self-diagnostic test that checks for abnormalities within the computer. This test is automatically carried out when the power is switched on for this computer. If the power is switched off during the POST, an error message is displayed the next time the computer is started up. Do not cut off the power during the POST.

4. Turning off the Power

Turning Off the Power

This item explains how to turn off the power.

Critical Points

- Do not turn back on the computer immediately after turning it off, but wait for 10 seconds or so.
- When the computer is not used for a long time, unload the floppy disk and the CD-ROM from the computer before turning it off.

- 1 **Click the [Start] button.**
The Start menu is displayed.

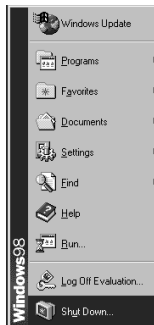

- 2 **Click [Shut Down].**
The following message is displayed.

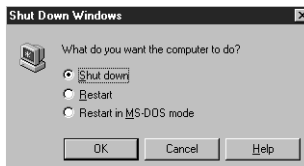

- 3 **[Check that Shut down the computer is selected, then click Yes].**
The power is turned off. If the computer will be unused for a long period, disconnect the AC adaptor.

Critical Points

- If the MAIN switch is not turned off after the step 3, press the SUS/RES button to turn on the personal computer next time.
- If “Restart” or “Restart computer” is selected on the dialog box that appears as a result of the steps 2, the personal computer will be restarted. “Restart” means that the personal computer erases all data saved in the memory once and again reads the program of the operating system from the floppy disk or hard disk into it.

4 Turn off the MAIN switch.

Slide the MAIN switch in the direction of the arrow (toward ○ side).

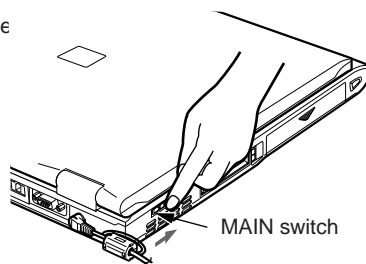
**Critical Point**

- If the personal computer won't be used for a long time after this step, be sure to disconnect the AC adaptor and to remove the battery pack from it.

5. Suspend/Resume Function

What Is the Suspend/Resume Function?

When this computer is suspended with the SUS/RES button, the suspend/resume function retains the programs and data in memory as is so that you can resume operations immediately the next time you press the SUS/RES button.

Precautions for Suspending

Pay attention to the following points when using the suspend function.

- Do not hold down the SUS/RES button for more than 4 seconds, otherwise the computer will be turned off.
- When the computer is connected to a network using a LAN or modem and when the peripheral equipment is expanded with a PC card, you may not be able to use the suspend/resume function. When you have expanded functions with a PC card, also check the manual for the cards you are using.
- Do not operate the SUS/RES button when using Windows NT.
- In the following cases, do not use the suspend function, but turn on/off the computer main unit power supply with the main switch.
 - When this computer is unused for a long period
When this computer will be unused longer than the effective period (about one day maximum) for battery power for suspend mode, save all data, close Windows 98, then turn off the main switch. If you suspend with the BIOS setup Suspend Mode set to Save to Disk, the power goes off with the main switch still on. In this case, it does not matter if you turn off the main switch. The next time you turn on the main switch, operation resumes.
 - When installing or removing options
There are some options that can be installed without turning off the main switch. See SECTION 2 of this manual and the manual that comes with the option product.

Critical Points

The SUS/RES button does not work in the following cases.



- If the battery is dead while the computer is powered from it.
- When the BIOS setup SUS/RES button is set to disabled.

Suspending

There are three ways to suspend this computer, using the SUS/RES button, Closed Cover switch and for Windows 98, using the [Shut Down] dialog.

● Using the SUS/RES button

1 Suspending

Check that  and  are out. When you press the SUS/RES button,  flashes and the computer goes into suspend mode.

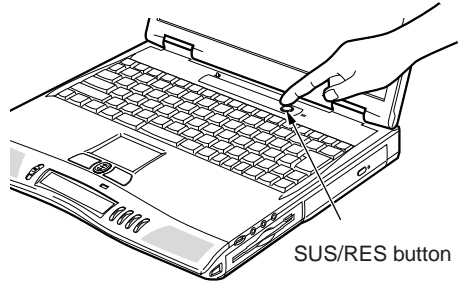

Critical Points

- Which of the two destinations suspending saves the data in the computer to depends on the BIOS setup Power menu setting as follows.
 - System RAM:**

When "Suspend" is set with the BIOS setup Power menu "Suspend Mode" item, the data is saved to system RAM. Power for the system RAM is supplied from the AC power supply if the AC adaptor is connected or from the battery if the AC adaptor is not connected.
 - Save to Disk area:**

If "Save to Disk" is set with the BIOS setup Power menu "Suspend Mode" item, the data is written to the Save to Disk area on the hard disk.
- If you hold down the **[Fn]** key while pressing the SUS/RES button, the data is saved to the hard disk regardless of the Power menu setting.

● **Using the Closed Cover switch**

1 Close the LCD display panel.

This unit goes into suspend mode using the Closed Cover switch.

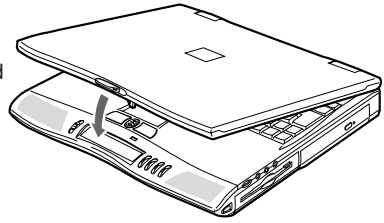

Critical Point

- When the BIOS setup “Lid Closure Suspend” setting is “Disabled”, this unit does not go into suspend mode even if you close the LCD display panel.

● **Using the [Exit Windows] dialog box.**

1 Click on the [START] button, then on [Exit Windows].

The [Exit Windows] dialog box will appear on the screen.

2 Choose [Standby] and click on [OK].

This computer is suspended.

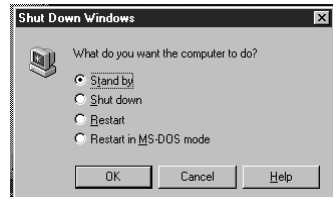

Critical Points

- If the BIOS setup Suspend Mode setting is “Suspend”, suspend mode is ended in the following cases. Save important data to a floppy disk or the hard disk.
 - The main switch is switched off.
 - In battery operation, the battery runs out. (The battery is still used in suspend mode.)
- If you start with the internal battery fully charged, suspend mode lasts about one day maximum with the AC adaptor not connected.

Using the Resume Function

You can make the computer resume the current application program, using either the SUS/RES button or the closed cover switch.

Critical Point

- Immediately after putting it into the Suspend mode, do not make the computer resume the program but wait for 10 seconds or so.

● Using the SUS/RES button

1 Press the SUS/RES button.

Pressing the SUS/RES button will cause the indicator ① on the status display panel to stop blinking and light up permanently, and will bring the computer into operation.

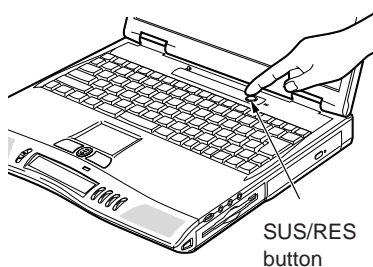

● Using the closed cover switch

1 Open the LCD display.

Opening the LCD display will turn on the Cover Close switch and make the computer resume the current program.

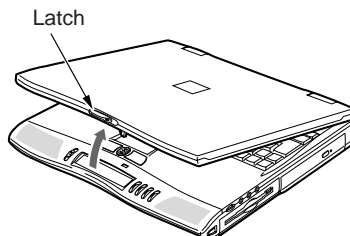

Critical Point

- The Resume function does not operate if Lid Open Resume in the BIOS Setup dialog box is not selected.

6. Battery

Battery Charging

For portability, this computer can operate either from the AC adaptor or from its battery. This item explains how to charge the battery.

1 Connect the AC adaptor.

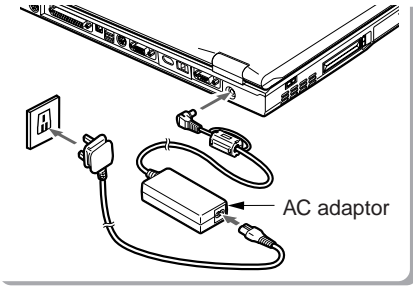

2  is displayed.

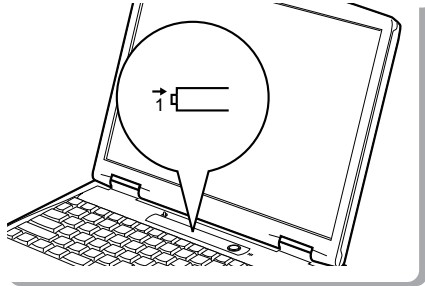



During charging,  is displayed on the status indicator LCD and the remaining battery charge is displayed.

● Relationship between computer modes and battery charging time

| Main switch | SUS/RES button | Computer mode | Charging mode | Charging time |
|-------------|----------------|----------------|-------------------|---------------|
| ON | Resume | Operating mode | Standard charging | About 9 hours |
| | Suspend | Suspend mode | Quick charge | About 3 hours |
| OFF | — | Stopped | | |

Critical Points

- When the battery charge indicator (➡) goes out and status of the remaining battery power indicator on the left side changes from blinking () to continuous lighting (), charging the battery is complete. Spend considerable hours for charging the battery so that it is fully charged.
- The battery capacity falls if the ambient temperature is too low or too high.
- Just after use of the battery, charging it may result in failure because the battery temperature has risen and the battery protection function is activated. In such the case, leave the battery in the charging status and charging will start a while later with drop of the battery temperature.

Battery Operation

This item explains operation with the battery.

- 1 Disconnect the AC adaptor and switch on the main switch.

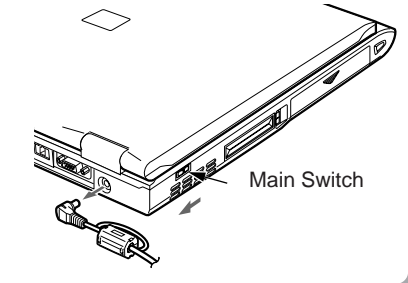

- 2 When the main switch is on, press the SUS/RES button.

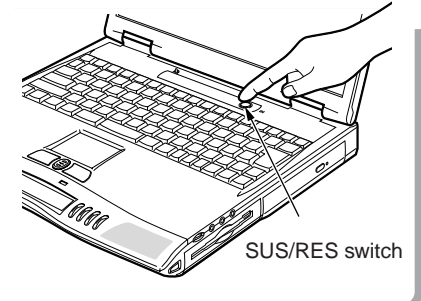

① stops flashing and stays lit up.

Critical Points

- When the ambient temperature is lower, the battery operating time is reduced.
 - With this computer, the battery operating time depends on the conditions under which the battery is used. However, the operating time of a new, fully-charged battery is about 1.5 to 3 hours.
- Condition: Main unit only, full charge, with power management on. (The yardstick for operating time depends on the conditions of use.)

Checking the Remaining Battery Charge

This computer can indicate the amount of battery charge remaining with the remaining battery charge indicator on the status indicator LCD.

● Remaining battery charge indicator



Indicates battery charge level of about 76% to about 100%



Indicates battery charge level of about 51% to about 75%



Indicates battery charge level of about 26% to about 50%



Indicates battery charge level of about 16% to about 25%



Indicates the low battery state (battery charge level of about 15% or lower).  flashes.



Indicates that the battery has run out (0% charge level).

● Battery abnormality indicator



Indicates that the battery can not be charged normally.

Critical Point

- When  is displayed, take out the battery pack and re-install it. If this display still remains, the battery pack is abnormal, so replace it.

Low Battery State

This item explains the display when this computer's battery is low and what to do.

1 The low battery is announced in the following way.

The warning beeps and the battery mark on the status indicator LCD flashes.

Critical Point

- If the audio volume is set too low, you may not be able to hear the warning beep. When the speaker is set to OFF using [Fn] + [F3] keys, the warning beep does not sound.

2 Press the SUS/RES button.

When the battery goes low, quickly press the SUS/RES button to suspend operation. Since the suspend/resume function works even if the computer is suspended during operation, the program and data are not lost.

Critical Point

- If you want to resume operation immediately, connect the AC adaptor, then press the SUS/RES button again.

3 Charge the battery.

Connect the AC battery to charge the battery.

Critical Points

- Reading from and writing to the hard disk uses large amounts of power. When saving data to the hard disk with the battery low, connect the AC adaptor.
- If you leave this computer running with the battery low, it is suspended automatically. However, if data is being read from or written to the hard disk or other media, the suspending waits until that processing is complete.
- If you continue using the computer with the battery low, in the worst case, the data being created or saved may be lost. Quickly connect the AC adaptor.

Replacing the Battery Pack

WARNING
(ELECTRIC SHOCK)



Before replacing the battery pack, be sure to turn off the computer and disconnect the AC adaptor from it. Otherwise you might get an electric shock.

- 1 Turn off the computer and disconnect the AC adaptor from it.

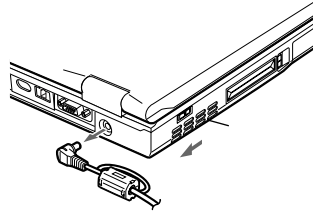

- 2 Slide the cover of the battery pack.

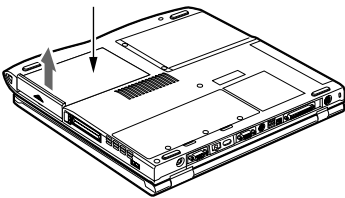

- 3 Slide the battery pack towards you (in the direction opposite to the connector).

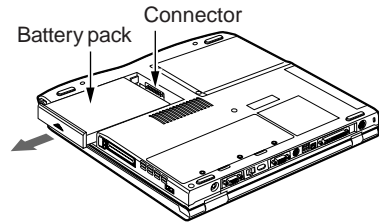

The battery pack is disconnected from the connector of the built-in battery pack slot.

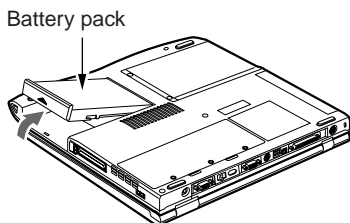
4 Remove the battery pack.

Tilt the battery pack up and then take it out of the battery pack slot in a tilt direction.

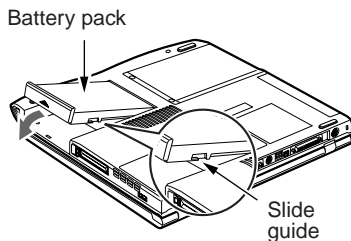
5 Install a new battery pack.

Put the battery pack in the slot by positioning the slide guide with the main unit.

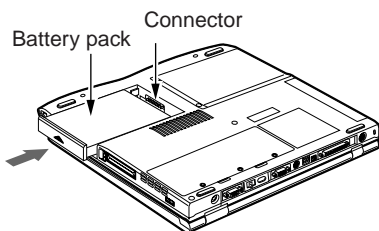
6 Connect the connector.

While tilting up the battery pack cover, slide the battery pack and connect the connector.

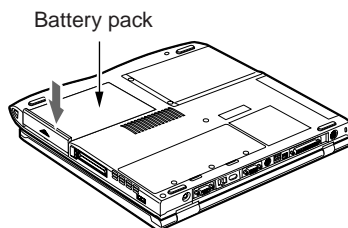
7 Slide the battery pack cover.

For locking the battery pack cover that was once slid in the previous step 2, again slide it to its original position.

Bridge Battery

The bridge battery is a NiCd battery that is built-in your notebook and is constantly being recharged. A bridge battery allows a charged Lithium ion battery to be exchanged for a discharged one by “warm-swapping”.

To warm-swap have a charged battery ready, put your notebook in Suspend mode, remove the low battery and quickly insert a charged battery. The bridge battery capacity is not large, about 3 minutes, and can vary with the condition of your notebook.



Caution



Data may be lost and/or system errors introduced if the warm swap is not performed quickly or a power adapter installed



Caution



The bridge battery can not support an operating notebook. The notebook must be in Suspend mode.

Precautions for Battery Pack



WARNING

(ELECTRIC SHOCK)



The battery pack is an extremely delicate products. When installing or removing one, do not drop it or subject it to strong shocks. If this should happen, do not use that battery pack in the interest of safety, because there is a risk of electric shock or malfunction.

● Discharge

After you charge the battery pack, even if you store it without using it, over about 1 month it will naturally discharge.

● Service life

- The battery pack is a consumption item. After you use it for a long time, its charging capacity drops.
- Replace the battery after about 300 to 500 charge/discharge cycles.
- When the battery operating time becomes extremely short, the battery has reached the end of its service life.

● To extend the battery operating time

Use the BIOS setup Power menu.

● Conditions under which the battery operating time becomes shorter

- Using in cold or hot location

The battery operating time is influenced by the environmental temperature and the battery operating time can be shorter at low temperature (5°C) than at high temperature (35°C). Also, high temperatures not only lower the charging efficiency, but are also a cause of battery pack deterioration.

- When the battery charging capacity drops

When the battery pack has been used for a long time, its charging capacity drops. In this case, replace it with a new battery pack.

● Use the AC adaptor in the following cases

- When using the hard disk or CD-ROM frequently
- When using a LAN or a modem

7. Floppy Disk Drive

Loading/Ejecting a Floppy Disk

This item explains how to load and eject a floppy disk.

● Loading

Insert into the floppy disk drive.

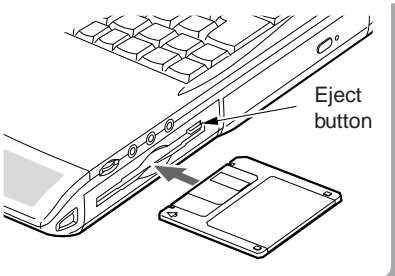

Insert the floppy disk with the label upwards and the shutter side first until the EJECT button springs out.

● Ejecting

Press the EJECT button.

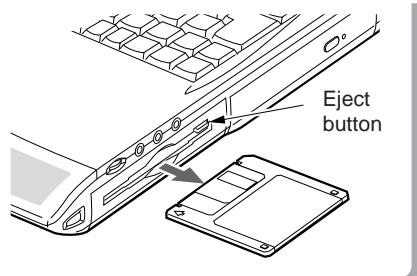

Check that the  on the Status Indicator LCD is not on, then press the EJECT button.

Critical Points

- If you eject the floppy disk while  is still indicated, there is a risk of losing the data on the disk.
- When you do not want to erase the data saved on the disk, or when you do not want to write additional data, slide the floppy disk's write protector so that the hole is open (WRITE PROTECT state). When you want to write data again, slide the write protector so that the hole is closed.

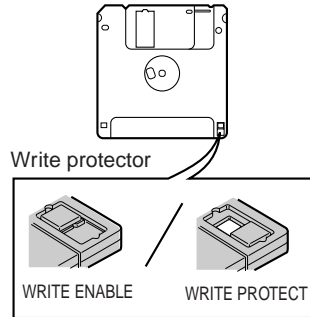

What is a Floppy Disk?

A floppy disk is a medium for storing programs or data. This item explains basic knowledge and precautions regarding floppy disks.

● Types of floppy disks

If floppy disks are classified according to the amount of data they can store (the memory capacity), typically there are the following 2 types.

● 2HD floppy disks

These have 1.44MB (megabyte: unit of data amount) and 1.2MB memory capacities.

● 2DD floppy disks

These have 720KB (kilobyte) memory capacities, half of the 2HDs.

The differences between the 2 kinds of floppy disks are shown in the diagram on the right.

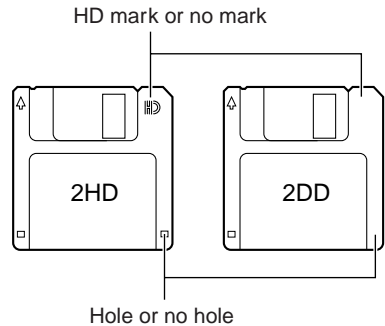

● 3 mode drive

This computer's floppy disk drive is a 3 mode drive that can read 1.44MB, 1.2MB and 720KB memory capacity floppy disks. Therefore it can read nearly all floppy disks. However, when exchanging data with another computer, you have to be careful if the other computer's floppy disk drive is not a 3 mode drive. For example, if the other computer can read 1.2MB floppy disks but not 1.44MB floppy disks, you have to enter the data after putting it into 1.2MB format in advance with this computer.

Critical Point

- Some floppy disks cannot be read by this computer, depending on the floppy disk format.

Precautions on Handling

Take the following precautions when using floppy disks in order to avoid damaging them.

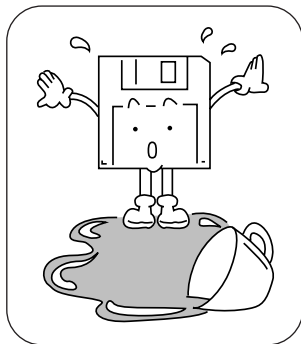

Be careful not to spill liquids such as coffee onto them.

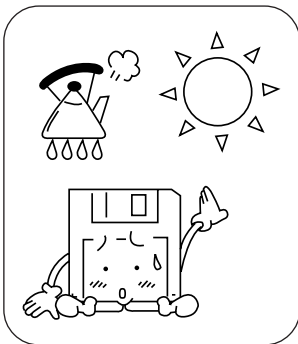

Do not place them in places with high temperatures or in direct sunlight.

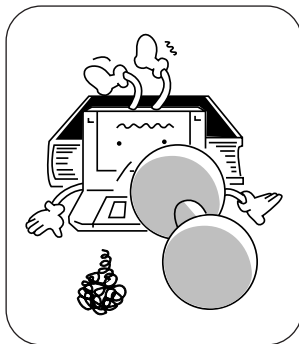

Do not bend them or place heavy objects on top of them.

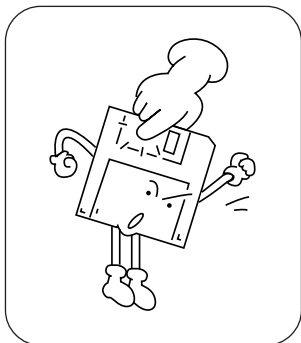

Never touch the surface of the disk.

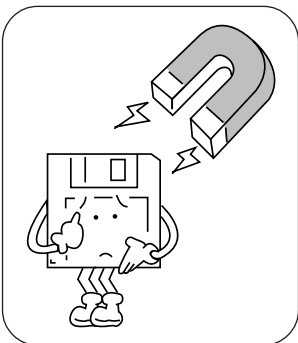

Do not bring them near to magnetic fields.

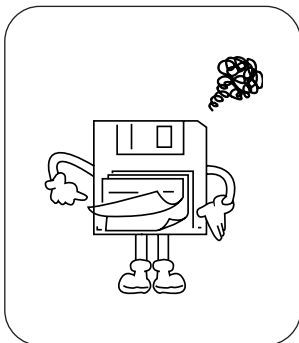

Do not stick labels on over each other.

8. CD-ROM Drive

CD-ROMs

Take the following precautions when handling CD-ROMS.

- When removing a CD-ROM from its case, lift it out while pressing the center holder of the case, as in the diagram on the right.
- Handle the CD-ROM by its edges, trying as much as possible not to touch the surfaces.
- Store the CD-ROM in its case when not using it.
- Do not leave it in a high temperature place.
- Do not bend it or place heavy objects on it.
- Do not write with a ballpoint pen, pencil, etc. on the label surface (printed side).
- If you suddenly move the CD-ROM from a cold place such as outside to a warm place, condensation will form on the surface and the CD-ROM drive will be unable to read data. If this happens, wipe the CD-ROM with a dry soft cloth, and then allow it to dry naturally. Do not use anything like a hairdryer, etc. to dry it.

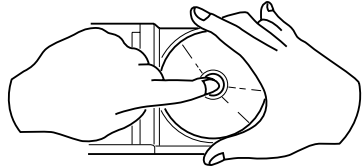

Critical Points

- If the CD-ROM gets dirty, wipe it clean with a dry soft cloth from the center outwards. Do not wipe it with benzine, paint thinner, water, record spray, antistatic solution or silicon cloth.
- A CD-ROM is a ROM that stores computer data instead of the audio data stored on music CDs (compact disks).
ROM stands for Read Only Memory, which means it is a memory medium that can only read data and cannot write data later. The CD-ROMs which are marked as in the diagram on the right can be used with this computer.
- A little time is required after installing a CD-ROM until the computer recognizes it.



Loading/Ejecting a CD-ROM

This item explains how to load/eject a CD-ROM.

Critical Point

- There is a protective sheet on the expansion unit's CD-ROM tray upon delivery. Remove this sheet when you use the CD-ROM drive.
- You can only install/eject a CD-ROM when the computer main unit is in operating mode because of the electronic lock of the CD-ROM drive.

1 Press the EJECT button.

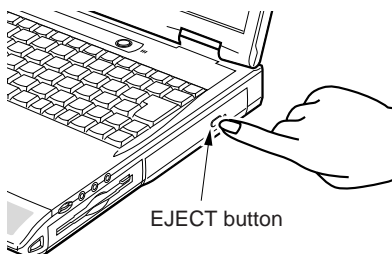

The tray springs out slightly.

2 Pull the tray out.

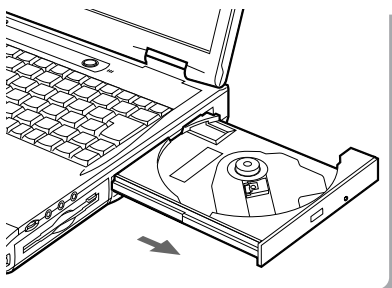

Pull the tray out gently.

3 Put in the CD-ROM.

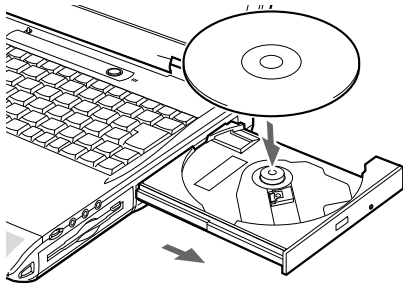

Place the CD-ROM in the center of the tray with its label facing upwards.

4 Set the tray.

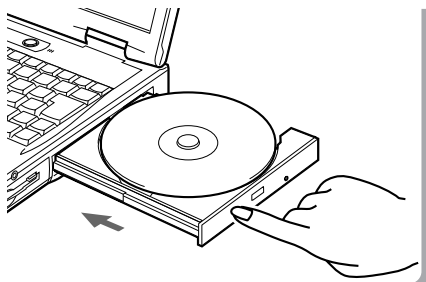

Push the tray in gently.

Critical Points

- CD-ROM drive is an extremely delicate device in which the CD-ROM revolves at high speed. Do not carry it when the power to the computer is switched on, and do not expose it to shocks or vibrations.
- When ejecting a CD-ROM, carry out the same procedure as for loading.
- If for some reason the tray does not come out when you press the eject button, insert something like a clip into the hole to the right of the EJECT button on the front of the CD-ROM drive unit and pull out the tray.

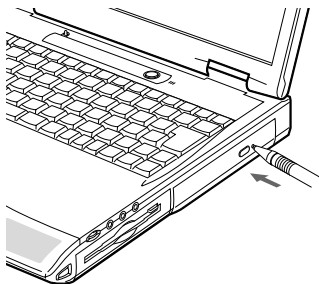

9. Internal Fax Modem

What is a Fax Modem?

A modem is a device for exchanging data between a computer and a telephone line. If you have a modem, you can carry out computer communications (connecting computers by a telephone line and exchanging information).

A fax modem is a modem which, in addition to the above functions, has a function of sending data to a fax machine. Therefore, when you transmit a document to another person's fax machine, you don't have to go to the trouble of printing out the document and setting it in your fax machine.

You can also receive data sent from a fax machine.

Connection

Connect the modular cable jack from the line junction into the modular connector on the rear of the computer main unit.

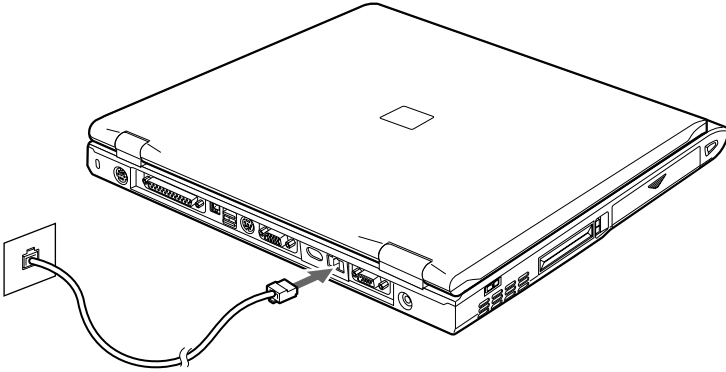

Critical Point

- When you remove the modular cable, press down the hook of the modular plug and pull it out.

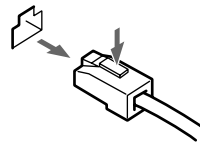

Modem Warnings



CAUTION

The internal modem has a maximum speed of 56000bps by ITU-T V.90 standard. Its maximum speed of 53000bps is the highest allowed by FCC, and its actual connection rate depends on the line conditions. The maximum speed is 33600bps at upload.



CAUTION

The internal modem is not intended for use with Digital PBX systems. Do not connect the internal modem to a digital PBX as it may cause serious damage to the internal modem or your entire notebook.

Consult your PBX manufacturer's documentation for details. Some hotels have digital PBX systems.

Be sure to find out **BEFORE** you connect your modem.

10. SPDIF Features

How to use the SPDIF Output Connector?

This model comes equipped with an Optical Digital Audio Out connector which allows you to connect to devices (Sony or Philips MiniDisc players) which supports SPDIF (Sony Philips Digital Interface) format. The SPDIF function in this system has been set to enabled.

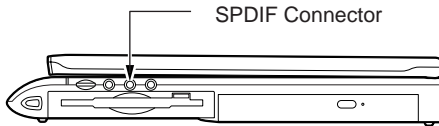

⚠ CAUTION (INJURY)



Do not look into the SPDIF connector when inserting the cable jack into the connector as there is a strong light beam emitting from the connector.

(BREAKDOWN)



Turn down the audio volume when connecting electronic devices to the Line In jack. Extremely loud audio volume will cause damage to the internal speakers.

Critical Point

- The frequency of the digital sound output from the SPDIF output connector is fixed at 48kHz. If a sampling rate convertor is not installed in your connected digital electronic device (e.g. MD player), recording is not possible. Please refer to the user's manuals for the electronic devices for further details.
- The sound recorded through the connected digital electronic device (e.g. MD player) to the SPDIF output connector cannot be used as a digital output. All output data from the SPDIF output connector has copyright protection information included.
- Please be careful to use the correct type of cable to connect the digital electronic device (e.g. MD player) to the SPDIF output connector. The type of connector that is used on your computer is a Optical Mini Plug (3.5mm diameter mini plug).

SECTION

2

This section explains installation of options for this computer.

1. Options

Options

You can expand the functions of this computer by connecting various options. Connecting options such as a printer or a modem card makes it possible to print documents created with this computer and to communicate them to other computers. Other options include hard disks and expansion memory. Install options to match this computer to your usage objectives.

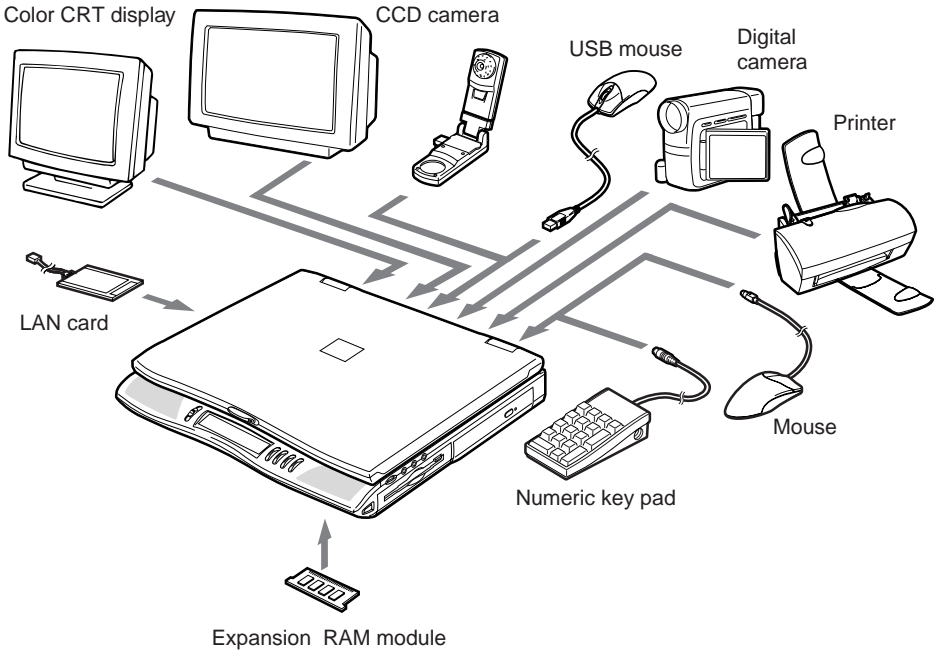

 **WARNING**
(ELECTRIC SHOCK)



Only connect equipment recommended by Fujitsu.
Connecting any other equipment can cause electric shock, fire, or breakdown.

 **CAUTION**
(INJURY)



When installing/removing options, do not remove any screws other than those specified by this manual.
Removing any other screws can cause injury and breakdown.

(BREAKDOWN)



Read this manual carefully and connect cables correctly. If you use this computer with cables connected incorrectly, this can cause breakdown of the computer main unit and of the peripheral equipment.

2. PC Cards

Precautions for PC Cards

Observe the following points when using PC cards to prevent breakdown.

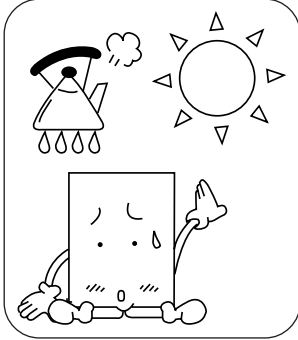

Do not place PC cards in high-temperature locations and locations subject to direct sunlight.

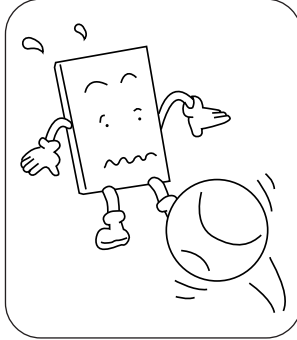

Do not subject PC cards to strong shocks.

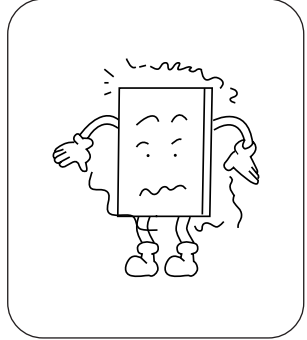

Avoid rubbing PC cards and building up static electricity.



Do not place heavy objects on top of PC cards.

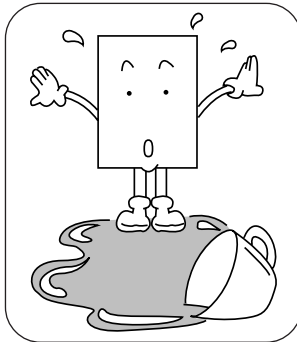

Be careful to avoid spilling coffee and other liquids on PC cards.

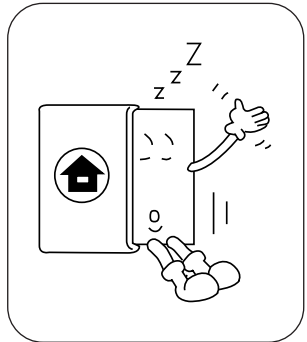

When storing a PC card, always place it in its special case.

Installing PC Cards

PC card is a generic term for business card sized cards which have a program and data memory function or peripheral equipment functions such as a modem or LAN adaptor. This item explains how to install a PC card.

1 Install the PC card.

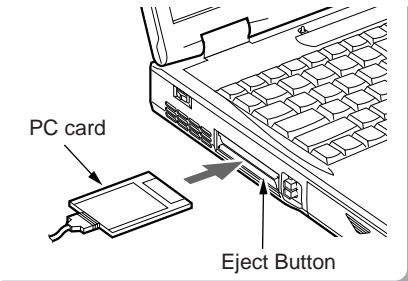

Insert the PC card into the PC card slot with the product name facing upwards.

Critical Points

- For some PC cards, the main power switch should be turned off. Refer to the manual attached to your PC card.
- In order to avoid damage, be careful not to knock or put anything on top of the connection point between the PC card and the cord.

Removing PC Cards

This item explains how to remove a PC card.

1 Click the PC card indicator on the task bar.

A message is displayed for stopping the installed PC card.



2 Click the PC card to be removed.

The PC card operations stop and the following screen is displayed.



Critical Point

- For IC memory cards, the "This device cannot be removed" message may appear. If this message does appear, close Windows 98 and turn off the computer main unit power before removing the IC memory card.

3 Click [OK].

4 Press the PC card eject button.

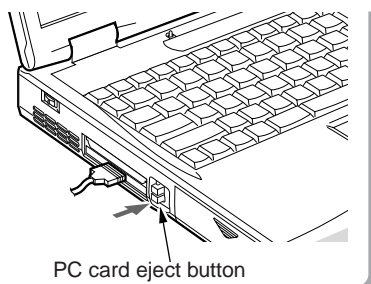

The PC card eject button slightly juts up.

5 Remove the PC card.

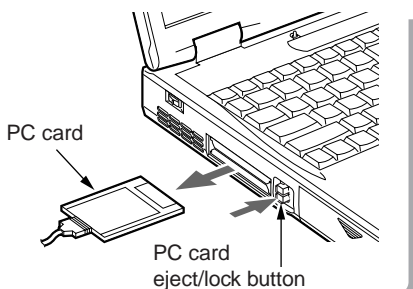

Press the PC card eject button to eject the PC card.

Critical Points

- Never remove a PC card by pulling on its cord. Yanking on the cord can break the PC card.
- Always use the procedure above for removing PC cards. Removing PC cards in any other way can cause breakdown.

3. Expansion RAM Modules

Installing an Expansion RAM Module

This item explains how to install expansion RAM modules.

! WARNING



Always turn off the computer and disconnect the AC adaptor when installing an expansion RAM module in order to avoid electric shock.

- 1 Turn off the computer and disconnect the AC adaptor.

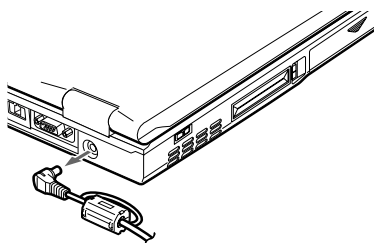

- 2 Remove the cover.

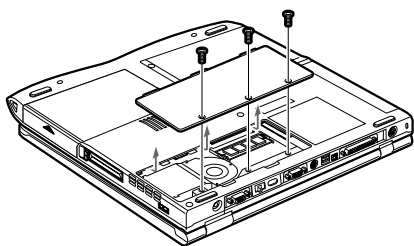

Take out the screws on the bottom of the computer main unit and remove the cover.

- 3 Install the expansion RAM module.

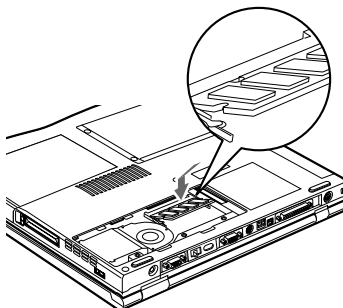

Align the notch of the expansion RAM module with the projection on the connector, insert firmly diagonally from above and push down until the module clicks into place.

4 Fit the cover.

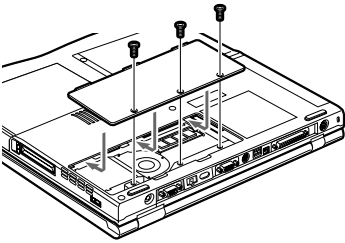

Fit the cover removed in 2.

CAUTION



The expansion RAM module is made up of parts that are extremely vulnerable to static electricity and can be damaged by the static electricity built up in the body. When installing or removing an expansion RAM module, hold it by the edges. Do not touch any terminals or ICs. Also, do not touch any parts or terminals within the computer main unit.

● Checking expansion memory

To check expansion memory after installing an expansion RAM module, look at the DIMM item in the Info menu of the BIOS setup. For example, when a 32MB expansion RAM module has been installed, the number displayed is 32MB. If the expansion RAM module has been installed correctly but the number has not increased, it means the RAM module is either broken or defective. If this happens, contact the store where the RAM module was purchased.

Removing an Expansion RAM Module

This item explains how to remove an expansion RAM module.

WARNING



Always turn off the computer and disconnect the AC adaptor when removing an expansion RAM module in order to avoid electric shock.

- 1 Turn off the computer and disconnect the AC adaptor from it.

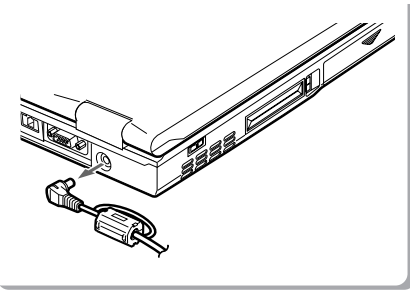

- 2 Remove the cover.

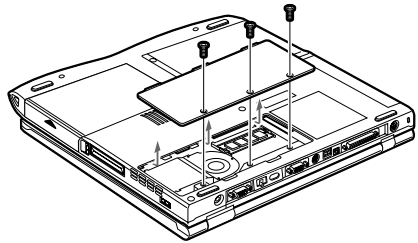

Remove the cover on the bottom of the computer main unit.

- 3 Remove the expansion RAM module.

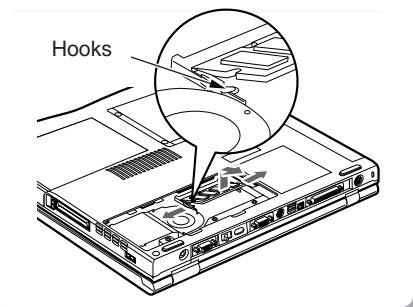

Open the hooks on both sides that retain the expansion RAM module to the left and right, then remove the expansion RAM module from the slot.

- 4 Fit the cover.

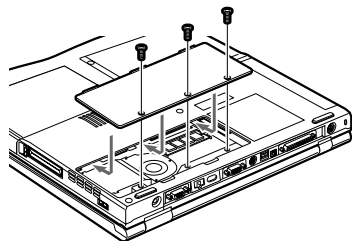

Fit the cover removed in 2.

4. Mouse

Connecting the Mouse

- 1 Turn off the computer and disconnect the AC adaptor from it.

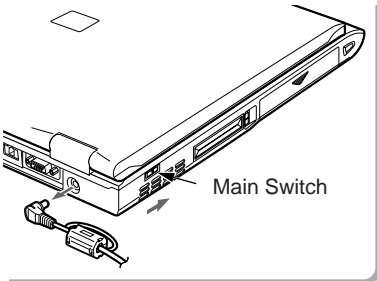

- 2 Connect the connector at the end of the mouse cable to the expansion keyboard/mouse connector on the rear side of the computer main unit.

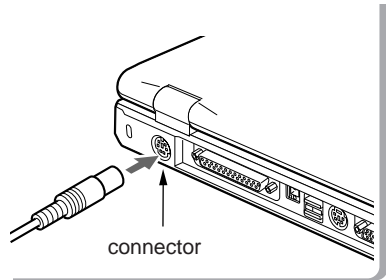

Have the arrow marked on the connector facing down.

Using the Mouse

● Moving the mouse

Place your hand on the mouse so that your fingers are resting on the left and right buttons and move the mouse by sliding it over your desktop or other smooth surface. The arrow (called the mouse pointer) on the screen moves in the same way as the mouse. Try moving the mouse while watching the screen.

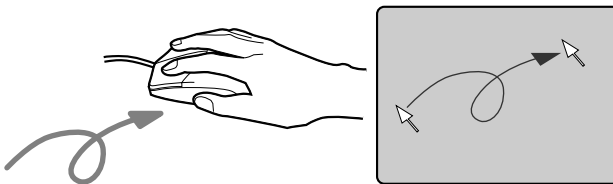

● Button operations

• Click

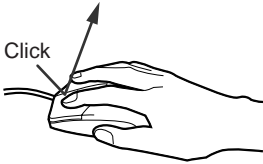

Press the left mouse button once until it clicks. The action of pressing the right button once firmly enough that it clicks is called a “right click”.

• Double click

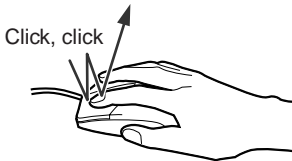

Press the mouse left button two times quickly in a row.

• Pointing

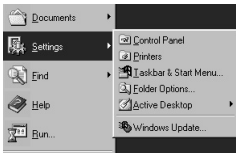

Align the mouse pointer with a menu item. When there is another level for the menu item the cursor is on (when ► is displayed at the right of the menu item), that menu level is displayed.



• Dragging

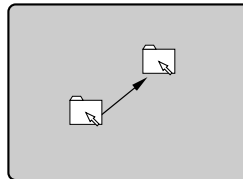
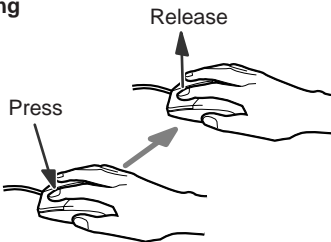

Move the mouse pointer with the mouse left button held down, then release the button at the desired position.

5. Numeric Keypad

Connecting a Numeric Keypad

This item explains how to connect a numeric keypad.

1 Turn off the MAIN switch.

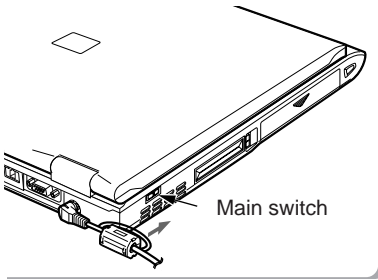

Slide the MAIN switch in the direction of the arrow (toward ○ side).

2 Connect the numeric keypad.

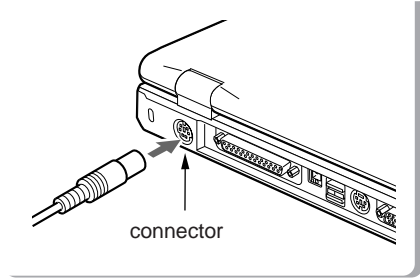

Have the arrow marked on the connector facing down.

Critical Points

- When a mouse is connected to the numeric keypad mouse connector, the mouse connector on the computer main unit cannot be used.
- You can adjust the tilt of the numeric keypad with the tilt feet on the bottom of the numeric keypad.

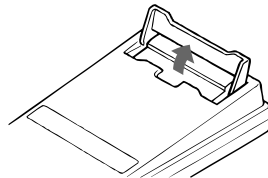
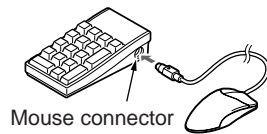

6. Printer

Connecting a Printer

This item explains how to connect a printer to the parallel interface connector on the rear of the computer main unit.

**WARNING**

(ELECTRIC SHOCK)



Always turn off the computer main unit and disconnect the AC adaptor before connecting/disconnecting a printer. Connecting/disconnecting a printer with the power on can cause electric shock.

**CAUTION**

(BREAKDOWN)



When connecting cables, read this manual carefully and make sure to connect correctly. Using this computer with cables incorrectly connected can cause breakdown of the computer main unit and the printer.

Critical Points

- Connecting a printer requires a printer cable. Sometimes this cable does not come with the printer. Even if the printer cable does come with the printer, sometimes it has the wrong configuration for this computer. In either of these cases, separately purchase a printer cable that you can connect to this computer.
- How to connect the printer depends on the printer. For details, refer to the printer manual.

-
- 1 Turn off the main unit and disconnect the AC adaptor.

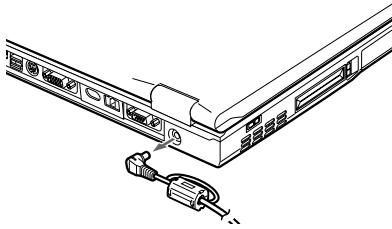

- 2 Connect the printer to the computer main unit.

Connect the printer cable securely at both ends and fasten securely at both ends with the screws and fixtures.

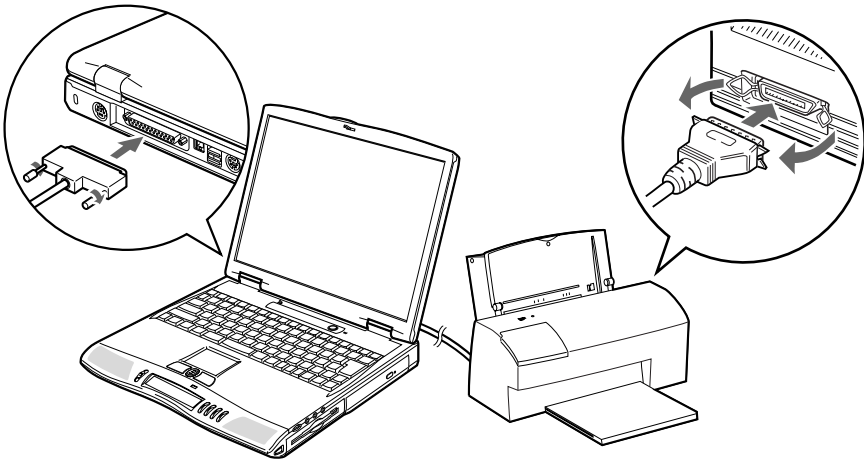

- 3 Connect the printer's power cord and turn on its power.
- 4 Connect the AC adaptor to the computer main unit and press the SUS/RES button.
- 5 Make the printer settings.

7. CRT Monitor / TV

Connecting an External CRT Monitor

An external CRT monitor can be connected to this computer. This item explains how to connect a CRT monitor to the CRT interface connector on the rear of the computer main unit.

⚠ WARNING (ELECTRIC SHOCK)



Always turn off the computer main unit and disconnect the AC adaptor before connecting/disconnecting a CRT monitor. Connecting/disconnecting a CRT monitor with the power on can cause electric shock.

⚠ CAUTION (BREAKDOWN)



When connecting cables, read this manual carefully and make sure to connect correctly. Using this computer with cables incorrectly connected can cause breakdown of the computer main unit and the CRT monitor.

- 1 Turn off the main unit and disconnect the AC adaptor.

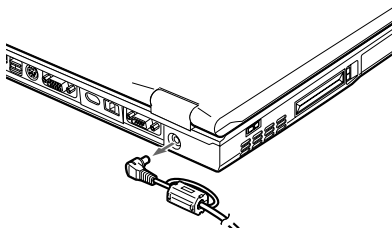

- 2 Connect the CRT monitor to the computer main unit.

Connect the CRT cable securely to the connectors at both ends and fasten securely at both ends with the screws.

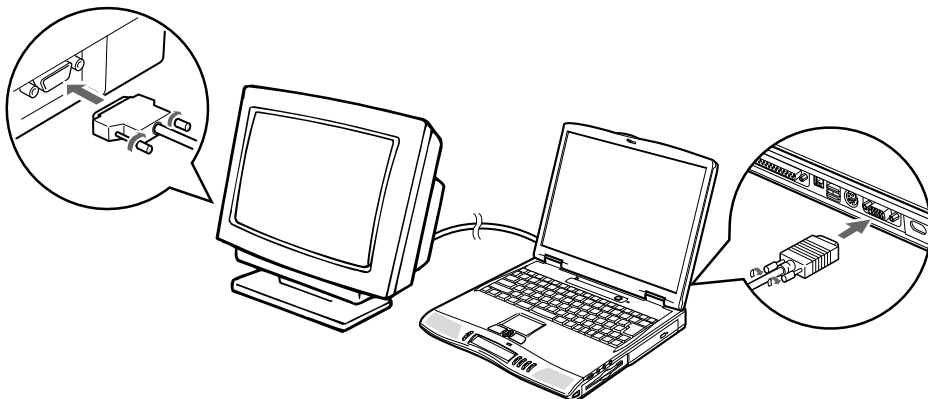

3 Connect the AC adaptor to the computer main unit and switch on main switch.

4 Connect the CRT monitor's power cord and press the SUS/RES button.

5 Switch the screen display.

When you press [Fn] + [F10], the display switches to the next step in the sequence: LCD → simultaneous display → CRT → LCD.

Connecting to a TV

This notebook comes with a S-video output located at the back of the notebook. You will need a S-video AV cable that comes standard with a TV

| | |
|-------------------------------|---|
| 1. TV | Prepare a S-video cable to be connected between the notebook and TV. |
| 2. AV cable (for S video out) | This cable doesn't come equipped with the notebook. It is readily sold in the market. |
| 3. TV's user manual | Each TV has different connection method. Please refer to the TV's user manual. |

BIOS Setup:

1. Switch on the notebook and press F2 key for BIOS setup
2. Select Advanced, Video Features
3. Set Enabled for TV Output
4. Set PAL or NSTC (depending on your location)
5. Esc and Save Changes.

Software setup:

1. Startup Windows Operating system
2. Go to control panel and select display icon
3. Select Settings and click Advanced button
4. Select ATI Displays
5. Click on the TV icon to enable display (if S-video cable is not connected, this function will not work)
6. Select OK when finished.

8. Wireless Mouse

This chapter explains fundamentals of handling and operation of the wireless mouse with matters that require attention. Before using the wireless mouse, carefully read this chapter so that you'll have a good knowledge to use this wireless mouse.

Precautions on safety

Strictly observe the following instructions for safe use of the wireless mouse.

- Before use, carefully read these safety precautions for using the wireless mouse correctly.
- After reading this guide, keep it handy for quick reference.

The following symbol with a word WARNING or CAUTION frequently appears in this chapter. Please read carefully and understand it.



WARNING

- If an external substance (metallic particle, water, etc.) gets into the wireless mouse, immediately contact the store that you purchased it. Don't use the mouse with a foreign substance inside because it may cause breakout of fire or electric shock.
- If the wireless mouse falls down or the cover is damaged, contact the store that you purchased. If such the mouse is continuously used as it is damaged, it may cause breakout of fire or electric shock.
- Don't use the wireless mouse in a place where flammable gas is generated to prevent accidental breakout of fire.
- Be sure to use the specified batteries only. Use of an unspecified battery may cause damage to the wireless mouse, breakout of fire or electric shock.

 **CAUTION**

- Don't leave the wireless mouse in a place where it is directly exposed to the sun or the temperature is expected to rise extremely, for example, in a car exposed to the scorching sun, for a long time. Extremely high temperature may cause the cover and other parts of the wireless mouse to be heated, deformed, melted, or to fire because its inside is heated.
- Avoid using the wireless mouse in a dusty or humid place. If the wireless mouse gets dust or moisture inside, it may cause failure of the mouse or outbreak of fire.
- Don't put the wireless mouse in a place where it is exposed to steam or soot such as in a kitchen or near a humidifier, because it may cause a fire.
- Neither dismantle the wireless mouse nor remove any part from it. If it is done so, it may cause fire or electric shock.
- Don't cover or wrap the wireless mouse with cloth or other thing. If done so, the mouse becomes hot because of poor radiation of heat and it may cause deformation of the cover and breakout of fire. Use the wireless mouse in a well-ventilated condition.
- Don't insert or drop a metallic particle, flammable thing or foreign substance into the wireless mouse. If there is a foreign substance inside the wireless mouse, it may cause a fire.
- Don't put the wireless mouse on a slant or unstable plane or in a place where it is easily affected by strong vibration. If the mouse falls down, it may cause damage to the mouse or injury to a person.
- Don't give a strong shock or vibration to the wireless mouse, otherwise the mouse may fall into failure.
- Don't clean the wireless mouse with thinner or benzene, or don't spray insecticide or the like to it. Such the chemical may cause the mouse to crack or catch fire.

Preparation and Preliminary knowledge

● Loading of batteries

Load the wireless mouse with two AAA-size alkaline batteries referring to the article “Replacing batteries” of this manual.

● H-L-OFF switch

Infrared transmission power of this wireless mouse can be switched between low and high with the H-L-OFF switch. Set this switch to the H (High power mode) or L (Low power mode) position taking the operating environment and conditions into consideration. When this mouse is out of use, set this switch to the OFF position for saving battery power.

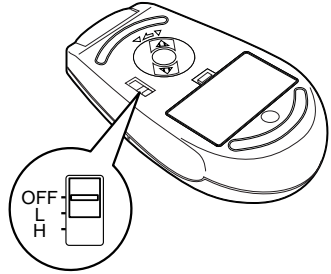

● Operating method

This wireless mouse transmits data on mouse operation to the personal computer on infrared rays. When operating the wireless mouse, point its transmitter part at the photosensor of the personal computer. The operating method of this wireless mouse is the same as the general PS/2 mouse.

It is recommended to use this wireless mouse within a distance of 1.5 m (High power mode) or 0.5 m (Low power mode) from the personal computer.

Critical Points

The one-touch operation buttons cannot be used in the following cases.

- The illustration of a personal computer appearing on this page is just a reference. The outward appearance slightly differs with the model. Before using this wireless mouse, check the personal computer for the location of the photosensor for the wireless mouse.

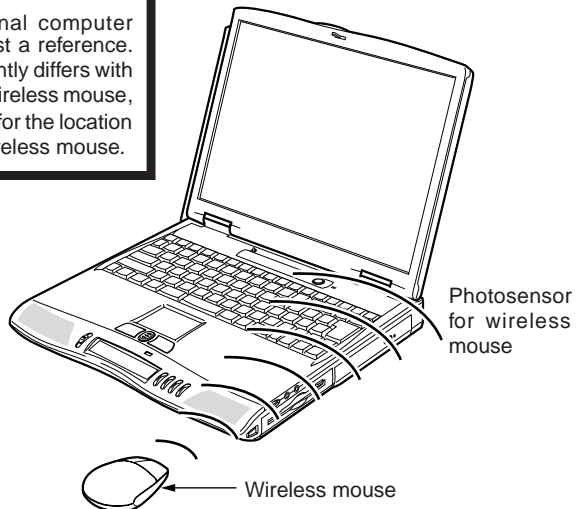

Setup of personal computer and wireless mouse

● Setup of personal computer

See Bios section to enable infrared mouse. Ensure that the setup menu is Enabled.

Critical Points

- When “enabled” is selected for the item of “Infrared mouse”, the external PS/2 mouse that is connected with the extension keyboard/mouse connector is unusable. Furthermore, set the item of “Built-in pointing device” of the “Setup of keyboard/mouse” submenu of the “Detailed menu” to “Always enabled”.

● Identification of mouse

If multiple wireless mice are used close to each other, it is needed to identify every wireless mouse with an individual identification code to avoid radio interference. For identify a wireless mouse, open the lid of the battery chamber on the bottom of the mouse and set an identification number with the DIP switch (refer to the table below).

For turning on/off each element of the DIP switch, use a pointed stick such as a ball-point pen or the like.

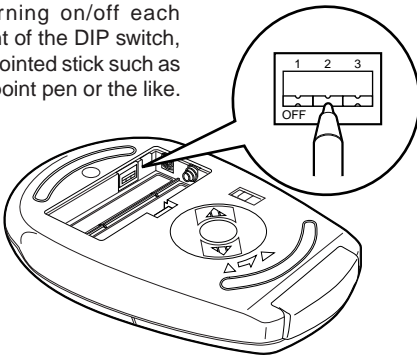

| ID | DIP switch | | |
|----|------------|----|----|
| | 1 | 2 | 3 |
| 0 | on | on | on |
| 1 | Off | on | on |
| 3 | on | on | on |
| 4 | Off | on | on |
| 5 | on | on | on |
| 6 | Off | on | on |
| 7 | on | on | on |

Critical Points

- On shipping a wireless mouse from the factory, its identification number is set at “7”.
- When the identification number of a wireless mouse is changed, turn off the personal computer once and again turn it on, or suspend the personal computer and resume it to make it recognize the new identification number of the mouse.
- The personal computer recognizes the identification code of a wireless mouse when it receives a signal of the identification code for the first time after it is turned on or resumed.

Replacing batteries

1 Remove the lid of the battery chamber.

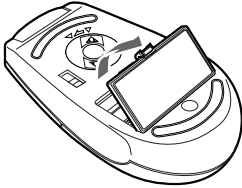

2 Remove the old batteries.

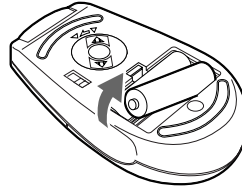

3 Set new batteries in the battery chamber. Pay heed to the polarities (+ and - poles) of each battery so as to set it in correct orientation.

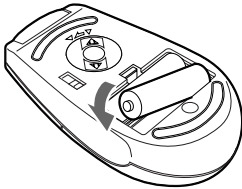

4 Fit the lid of the battery chamber to the wireless mouse.

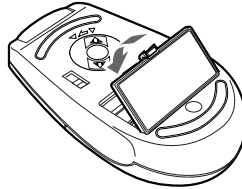

CAUTION

- Check the orientation (directions of + and - poles) of each battery so that it is correctly set in the battery chamber.
- Don't use a used battery mixedly with a new battery or two new batteries that are different in brand or rating from each other.
- When the wireless mouse won't be used for a long time, remove the batteries to prevent it from trouble such as leak of electrolyte. If electrolyte leaks from the battery, clean the inside of the battery chamber, particularly metal terminals, and its periphery with soft cloth that is moistened with water once and then tightly squeezed to remove electrolyte, and carefully wipe out moisture with dry soft cloth.
- When you get electrolyte on your body, carefully wash it out with water. If electrolyte gets into your eyes or mouth, immediately wash it out with water and consult a doctor as soon as possible.
- Be careful not to make a short-circuit between terminals of the battery chamber.
- Don't put any battery in water or fire. Don't take any battery apart to pieces.
- Don't charge the battery of this wireless mouse.
- Don't directly solder the battery.
- Don't keep batteries in an extreme temperature condition.
- Don't give a strong shock to batteries.
- When disposing used batteries, follow the regulations and directions of the local autonomy concerned.

For good maintenance

If the ball or roller of the wireless mouse gets dust or soiled, it may cause malfunction of the mouse. Be sure to clean the mouse regularly (once a month or so) according to the following procedure.

1 Remove the mouse ball cover.

Turn the mouse ball cover in the direction of the arrow and remove it.

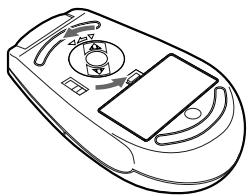

2 Remove the ball from the mouse.

Lift the mouse with a hand and receive the ball falling down with the other hand. Wash the ball with water and dry it up.

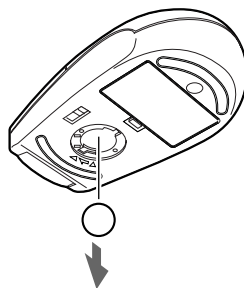

3 Clean the inside of the mouse.

Wipe down the roller, inside of the ball chamber and cover with dry soft cloth.

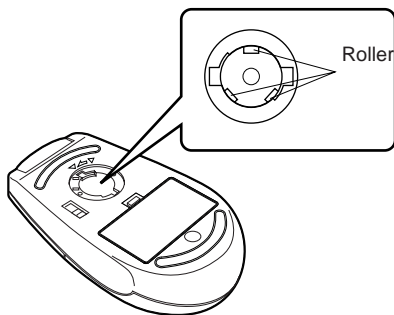

4 Restore the ball and cover to their original positions.

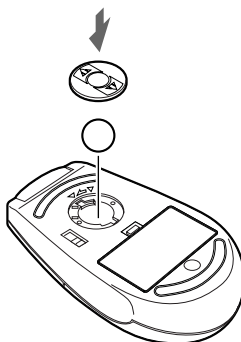

CAUTION

- Don't leave moisture inside the mouse. Don't use any organic solvent such as alcohol, benzene, etc. for cleaning.

Caution

- Don't use the wireless mouse pointing it at the infrared communication port of the personal computer to avoid malfunction of the infrared communication port.
If the button of the wireless mouse is held depressed, the battery is depleted in a short time.
- Don't put anything on the mouse and don't leave the mouse upside down.
- Don't expose the photosensor of the personal computer directly to the sun or a strong light, otherwise the personal computer may malfunction or communication distance may be shortened.

Troubleshooting

If the wireless mouse malfunctions, check the following matters. If the trouble still remains in spite of your check and measure, consult with the store that you purchased the computer/mouse.

| Symptom | Check point | Measures |
|--------------------------|---|---|
| Inoperative | Are the batteries set correctly? | Set the batteries correctly (in correct orientation). |
| | Is the mouse pointed at the photosensor of the personal computer? | Point the transmitter of the mouse at the photosensor. |
| | Is there anything obstructive between the mouse and photosensor of the personal computer? | Remove the obstruction, if there is. |
| | Is the mouse operated in the receiving range of the photosensor of the personal computer? | Relocate the personal computer or mouse in the receiving/transmitting range of the photosensor/mouse. |
| Radio interference | Are the multiple wireless mice identified by their individual identification codes? | Identify the respective mice by individual identification codes. |
| Abnormal mouse operation | The batteries are depleted, aren't they? | Replace the batteries with new ones. |
| | The ball or roller of the mouse gets dust or soiled, doesn't it? | Clean the inside of the mouse. |

Specifications

| Item | Description |
|--|--|
| Transmission system | Infrared transmission |
| Service life of battery (alkaline battery) (in Low Power mode) | 6 months approximately (under operating conditions: 8-hours/day, 5-days/week, net operating rate of mouse = 10 %) (condition not in use: power off, temperature 20 degree centigrade) |
| Operable range | H: Distance - within 1.5 m, angle - right and left 0 degree, Up and down 0 degree L: Distance - within 0.5 m, angle - right and left +45 degrees and - 45 degrees , up 45 degrees , down 15 degrees |



CAUTION

- This wireless mouse falls under the class B information processor conforming to the VCCI (Voluntary Control Conference Against Jamming Caused by Information Processor) standard.
This wireless mouse is designed to be used in the standard home environment, however, if it is used near a radio or TV set, it may cause radio interference.
Use this wireless mouse correctly following the instructions of this user's guide.

SECTION

3

1. BIOS setup

Snapshots of the BIOS setup screen and the possible setup options is shown in the following sections.

- Underlined setup options show the default settings.
- Columns between Selections and Note show the security level of each setup item. 'S' means that the item needs the supervisor password security level and can not be changed with the user password security level.
- Setup screen may differ slightly depending on the option devices installed in your system

1.1 Main Menu

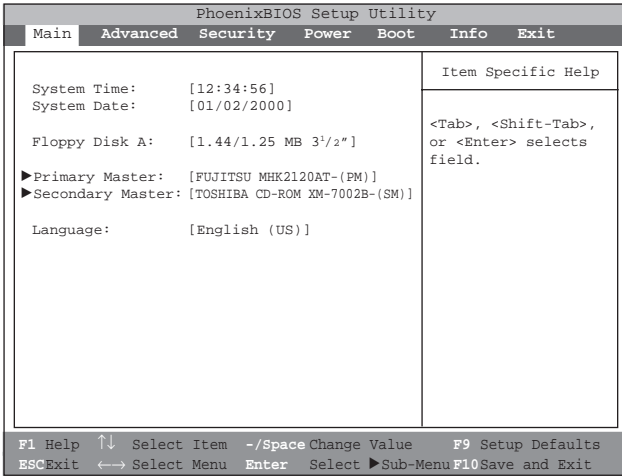

Figure 1-1 Main menu

| Setup Item | Selections | Note (Item Specific Help) |
|------------------|------------------------------------|---|
| System Time | 00:00:00 to 23:59:59 | Adjust calendar clock. <Tab>, <Shift-Tab>, or <Enter> selects field. |
| System Date | 01/01/1981 to 12/31/2099 | Adjust calendar date. <Tab>, <Shift-Tab>, or <Enter> selects field. |
| Floppy Disk A | Disabled 1.44/1.25 MB 3 1/2" | S Select Floppy Disk type. Note that 1.25 MB, 3 1/2" references a 1024 byte/sector Japanese media format. |
| Primary Master | | Configures ATA/ATAPI device. |
| Secondary Master | | Configures ATA/ATAPI device. |
| Language | <u>English (US)</u> xxxxxx (JP) | Select the display language for the BIOS. |

Table 1-1 Main menu options

1.1.1 Main - Primary Master, Secondary Master Menu

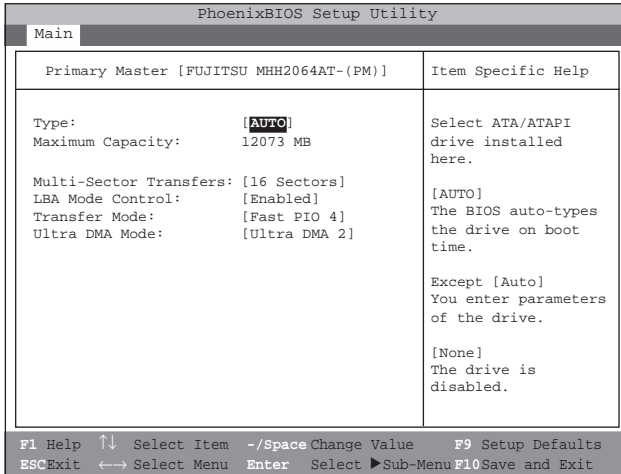

Figure 1-2 Main - Primary/Secondary Master Menu

Setup Item Type

Selections

Auto
 None
 CD-ROM
 ATAPI Removable
 Hardisk

Note (Item Specific Help)

Select ATA/ATAPI device type. If 'Auto' is selected, the type is automatically identified at POST by the BIOS. It does not carry out Cylinder/Head/Sector display in the case of over 8.4GB-HDD when Auto mode. Hard Disk = you enter parameters of hard-disk drive installed at this connection. CD-ROM = a CD-ROM drive is installed here. ATAPI Removable = removable disk drive is installed here. If 'None' is selected, all of the following setup items do not appear. When 'User' is selected, you can specify Cylinders, Head and Sectors. Auto=autotypes ATA/ATAPI drive installed here.

Maximum Capacity xxxx MB

Display maximum capacity calculated from parameters of hard disk when 'Auto' is selected and the type is identified as hard disk, or 'User' is selected.

Multi-Sector Transfers Disabled
 2 Sectors
 4 Sectors
 8 Sectors
 16 Sectors
 MAX 32
 MAX 64
 MAX 128

S This option can not be changed when 'Auto' is selected. Specify the number of sectors per block for multiple sector transfer. 'MAX' refers to the size the disk returns when required.

| Setup Item | Selections | Note (Item Specific Help) |
|-------------------|---|--|
| LBA Mode Control | <u>Disabled</u> Enabled | S This option can not be changed when 'Auto' is selected. Enabling LBA causes Logical Block Addressing to be used in place of Cylinders, Heads & Sectors. |
| Transfer Mode | <u>Standard</u> Fast PIO 1 Fast PIO 2 Fast PIO 3 Fast PIO 4 Fast PIO 3 / DMA Fast PIO 4 / DMA | S This option can not be changed when 'Auto' is selected. Multi-word DMA is automatically set to mode 1 for 'Fast PIO 1', 'Fast PIO 2', 'Fast PIO 3' and set to mode 2 for 'Fast PIO 4'. Selects the method of moving data to/from the drive. Autotype the drive to select the optimum transfer mode. |
| Ultra DMA Mode | <u>Disabled</u> Mode 0 Mode 1 Mode 2 | S You can not change this option when 'Auto' is selected. Selects the Ultra DMA mode used for moving data to/from the drive. Autotype the drive to select the optimum transfer mode. |

Table 1-2 Main - Primary/Secondary Master menu options

1.2 Advanced Menu

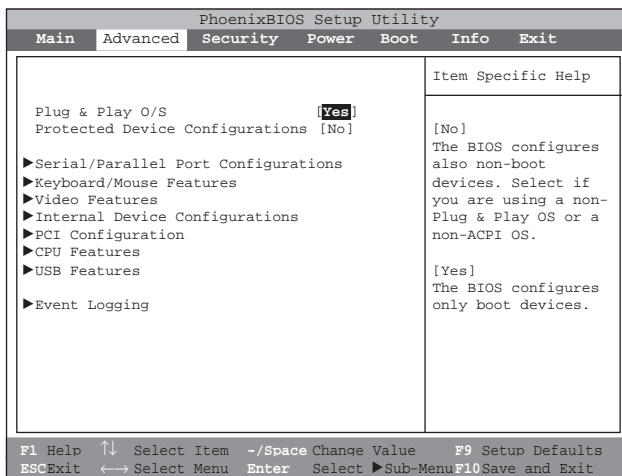

Figure 1-3 Advanced menu

| Setup Item | Selections | Note (Item Specific Help) |
|------------------------------------|------------------|---|
| Plug & Play O/S | No <u>Yes</u> | S Select 'Yes' if you are using a Plug & Play capable operating system. Select 'No' if you need the BIOS to configure non-boot devices. |
| Protected Device Configurations | <u>No</u> Yes | S 'Yes' prevents a Plug and Play Operating System from changing system settings. |
| Serial/Parallel Port Configuration | | Configures serial port and parallel ports. |
| Keyboard/Mouse Features | | Setup keyboard/mouse features. |
| Video Features | | Setup display and video features. |
| Internal Device Configurations | | Configures other internal devices. |
| CPU Features | | Configures CPU features. |
| USB Features | | Configures USB features. |
| Event Logging | | Configure Event logging. |

Table 1-3 Advanced menu options

1.2.1 Advanced - Serial/Parallel Port Configuration Menu

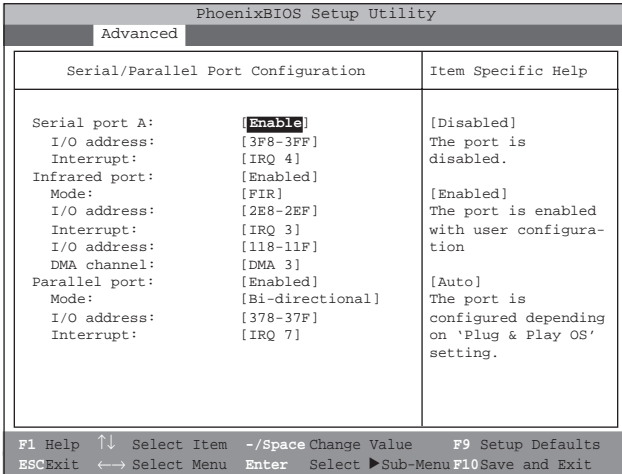

Figure 1-4 Advanced - Serial/Parallel Port Configuration menu

| Setup Item | Selections | Note (Item Specific Help) |
|---------------|--|---|
| Serial port A | Disabled Enabled Auto | S Configure serial port A using options: [Disabled] No configuration [Enabled] User configuration [Auto] BIOS or OS chooses configuration. |
| I/O address | 3F8 - 3FF 2F8 - 2FF 3E8 - 3EF 2E8 - 2EF | S This option is available when Serial port A is 'Enabled'. Set the base I/O address for serial port A. |
| Interrupt | IRQ 3 IRQ 4 IRQ 10 IRQ 11 | S This option is available when Serial port A is 'Enabled'. Set the interrupt for serial port A. |
| Infrared port | Disabled Enabled Auto | S Configure serial port B using options: [Disabled] No configuration [Enabled] User configuration [Auto] BIOS or OS chooses configuration |
| Mode | IrDA FIR | S This option is available when Serial port B is 'Enabled'. Set the mode for serial port B. |
| I/O address | 3F8 - 3FF 2F8 - 2FF 3E8 - 3EF 2E8 - 2EF | S This option is available when Serial port B is 'Enabled'. Set the base I/O address for serial port B. |

| Setup Item | Selections | Note (Item Specific Help) |
|---------------|--|--|
| Interrupt | <u>IRQ 3</u> <u>IRQ 4</u> <u>IRQ 10</u> <u>IRQ 11</u> | S This option is available when Serial port B is 'Enabled'. Set the interrupt for serial port B. |
| I/O address | <u>100 - 107</u> <u>108 - 10F</u> <u>110 - 117</u> <u>118 - 11F</u> | S This option is available when Mode for Serial port B is set to 'FIR'. Set the base I/O address for the FIR of serial port B. |
| DMA channel | <u>DMA 1</u> <u>DMA 3</u> | S This option is available when Mode for Serial port B is set to 'FIR'. Set the DMA channel for the FIR of serial port B. |
| Parallel port | <u>Disabled</u> <u>Enabled</u> <u>Auto</u> | S Configure parallel port using options: [Disabled] No configuration [Enabled] User configuration [Auto] BIOS or OS chooses configuration |
| Mode | <u>Output only</u> <u>Bi-directional</u> <u>ECP</u> | S This option is available when Parallel port is 'Enabled'. When you change this mode to 'ECP', 'DMA 1' is selected by default. Set the mode for the parallel port. |
| I/O address | <u>378 - 37F</u> <u>278 - 27F</u> <u>3BC - 3EF</u> | S This option is available when Parallel port is 'Enabled'. Set the base I/O address for the parallel port. |
| Interrupt | <u>IRQ 5</u> <u>IRQ 7</u> | S This option is available when Serial port B is 'Enabled'. Set the interrupt for the parallel port. |

Table 1-4 Advanced - Serial/Parallel Port Configuration menu options

1.2.2 Advanced - Keyboard/Mouse Features Menu

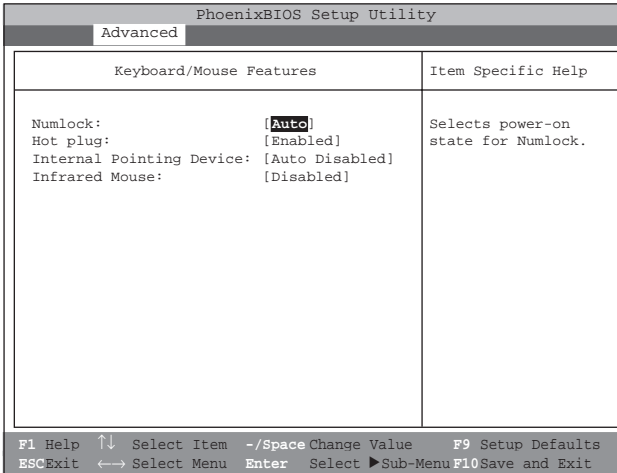

Figure 1-5 Advanced - Keyboard/Mouse Features menu

| Setup Item | Selections | Note (Item Specific Help) |
|--------------------------|--|---|
| Numlock | <u>Auto</u> On Off | S Selects Power-on state for Numlock. |
| Hot Plug | Disabled <u>Enabled</u> | S Keyboard/Mouse Hot Plug functions. |
| Internal Pointing Device | <u>Auto Disabled</u> Always Enabled | S If Always Enabled is selected, the internal pointing device is always enabled. If Auto Disabled is selected, the internal pointing device is disabled when an external pointing device is connected with the PS/2 port. However, if no pointing device is connected, the internal pointing device is enabled. |
| Infrared Mouse | <u>Disabled</u> Enabled | S If Infrared Mouse is enabled, PS/2 external pointing device will be disabled. To use internal pointing device simultaneously, please select "Always Enabled" in Internal Pointing Device menu. |

Table 1-5 Advanced - Keyboard/Mouse Features menu options

1.2.3 Advanced - Video Features Menu

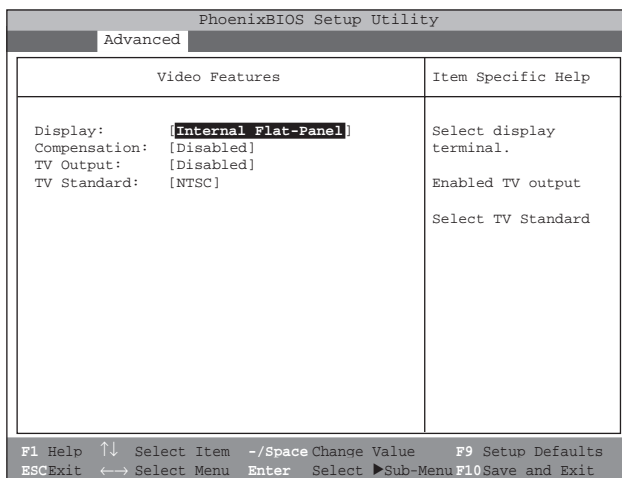

Figure 1-6 Advanced - Video Features menu

| Setup Item | Selections | Note (Item Specific Help) |
|--------------|---|---------------------------|
| Display | <u>F</u> lat-Panel C <u>R</u> T S <u>i</u> multaneous | Select display terminal. |
| Compensation | <u>D</u> isabled E <u>n</u> abled | Select compensation. |
| TV Output | [D <u>i</u> sabled] | Enabled TV output. |
| TV Standard | [N <u>T</u> SC] | Select TV standard. |

Table 1-6 Advanced - Video Features menu

1.2.4 Advanced - Internal Device Configurations

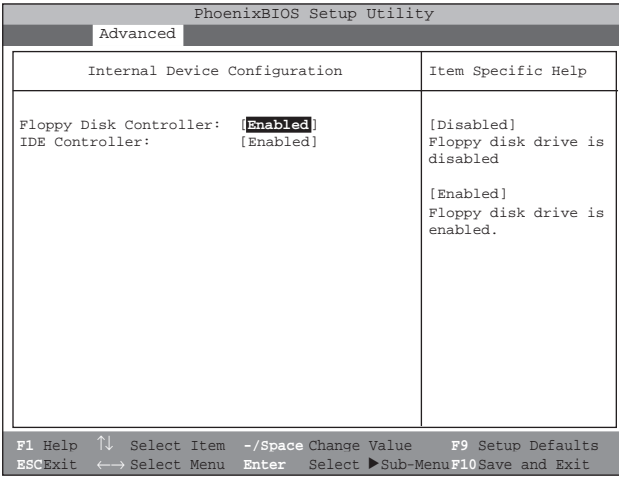

Figure 1-7 Advanced - Internal Device Configuration menu

| Setup Item | Selections | Note (Item Specific Help) |
|------------------------|----------------------------|-------------------------------------|
| Floppy Disk Controller | <u>Enabled</u> Disabled | Enables the floppy disk controller. |
| IDE Controller | <u>Enabled</u> Disabled | Enables the IDE port. |

Table 1-7 Advanced - Internal Device Configuration menu options

1.2.5 Advanced - PCI Configuration Menu

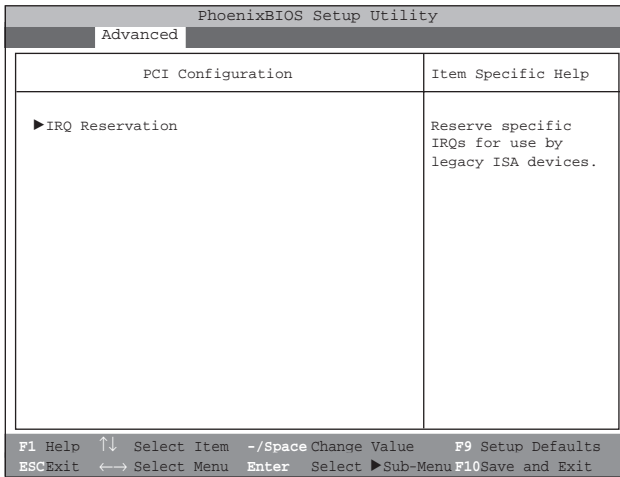

Figure 1-8 Advanced - PCI Configuration menu

Setup Item
IRQ Reservation

Selections

Note (Item Specific Help)
Reserve specific IRQs for use by legacy ISA devices.

Table 1-8 Advanced - PCI Configuration - IRQ Reservation menu options

1.2.5.1 Advanced - PCI Configuration - IRQ Reservation Menu

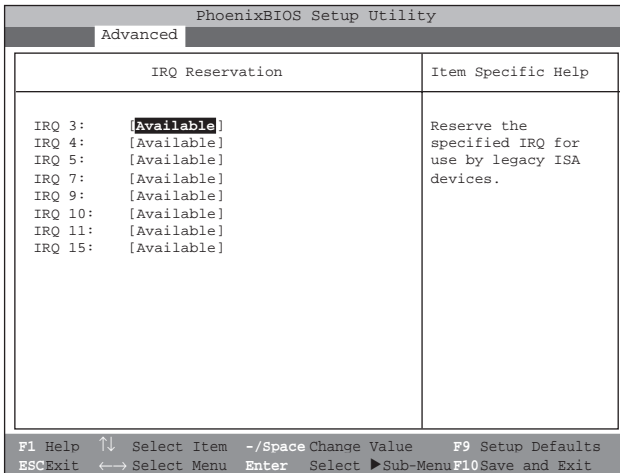

Figure 1-9 Advanced - PCI Configuration - IRQ Reservation menu

| Setup Item | Selections | | Note (Item Specific Help) |
|------------|------------------------------|---|---|
| IRQ 3 | <u>Available</u> Reserved | S | If [Reserved] is selected, the BIOS reserves IRQ 3 for use by legacy ISA devices and does not use it for embedded PCI or ISA devices. IRQ 3 is removed from the IRQ bitmap in the PCI IRQ routing table. Reserve the specified IRQ for use by legacy ISA devices. |
| IRQ 4 | <u>Available</u> Reserved | S | Reserves IRQ 4. Reserve the specified IRQ for use by legacy ISA devices. |
| IRQ 5 | <u>Available</u> Reserved | S | Reserves IRQ 5. Reserve the specified IRQ for use by legacy ISA devices. |
| IRQ 7 | <u>Available</u> Reserved | S | Reserves IRQ 7. Reserve the specified IRQ for use by legacy ISA devices. |
| IRQ 9 | <u>Available</u> Reserved | S | Reserves IRQ 9. Reserve the specified IRQ for use by legacy ISA devices. |
| IRQ 10 | <u>Available</u> Reserved | S | Reserves IRQ 10. Reserve the specified IRQ for use by legacy ISA devices. |
| IRQ 11 | <u>Available</u> Reserved | S | Reserves IRQ 11. Reserve the specified IRQ for use by legacy ISA devices. |
| IRQ 15 | <u>Available</u> Reserved | S | Reserves IRQ 15. Reserve the specified IRQ for use by legacy ISA devices. |

Table 1-9 Advanced - PCI Configuration - IRQ Reservation menu options

1.2.5.2 Advanced - CPU Features

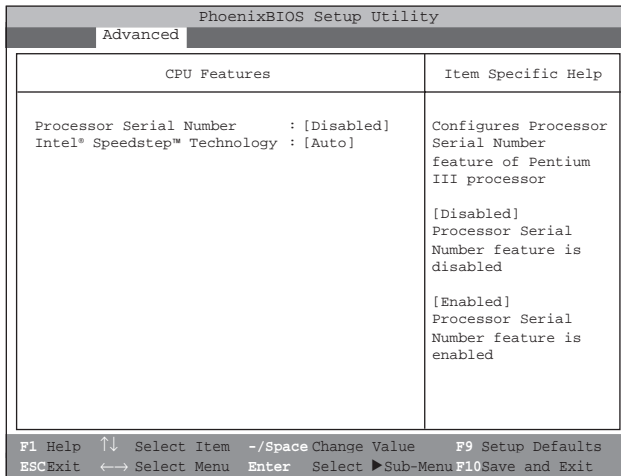

Figure 1-9a Advanced - CPU Features

| Setup Item | Selections | Note (Item Specific Help) |
|------------------------------|--------------|---|
| Processor Serial Number | [Disabled] | Configures Processor Serial Number feature of Pentium III processor |
| Intel® Speedstep™ Technology | <u>A</u> uto | CPU Speed is changed based upon power source change |
| | Max. Port | [Max.Port] CPU speed is maximized |
| | Batt Opt | [Batt Opt] CPU speed is optimized for battery operation. |
| | Disabled | [Disabled] CPU speed is fixed to the battery optimized speed. |

1.2.6 Advanced - USB Features

| PhoenixBIOS Setup Utility | |
|--|---|
| Advanced | |
| USB Features | Item Specific Help |
| USB Floppy Disk: [Disabled] | [Disabled] Legacy Floppy Emulation is disabled. [Enabled] legacy Floppy Emulation is enabled and USB floppy is available without USB aware OS. |
| F1 Help ↑↓ Select Item ~/Space Change Value F9 Setup Defaults ESC Exit ←→ Select Menu Enter Select ▶ Sub-Menu F10 Save and Exit | |

Figure 1-10 Advanced - USB Features

| Setup Item | Selections | Note (Item Specific Help) |
|------------|-----------------|---|
| | <u>Disabled</u> | Legacy Floppy Emulation is disabled. |
| | Enabled | Legacy Floppy Emulation is enabled and USB floppy is available without USB aware OS |

Table 1-10 Advanced - USB Features

1.2.7 Advanced - Event Logging Menu

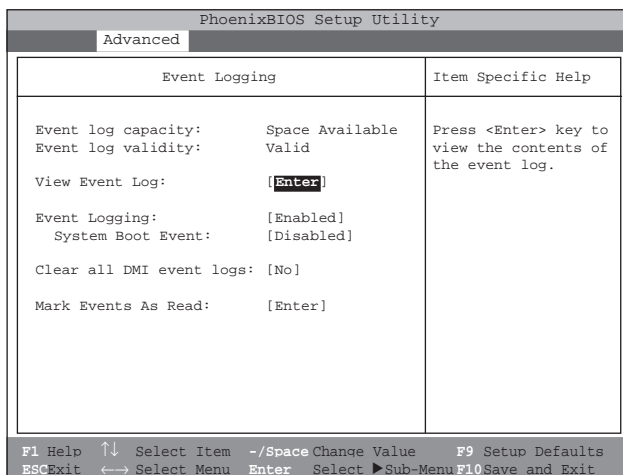

Figure 1-11 Advanced - Event Logging menu

| Setup Item | Selections | Note (Item Specific Help) |
|----------------------|----------------------------|--|
| Event log capacity | | Display event log capacity. |
| Event log validity | | Display event log validity. |
| View event log | Enter | S Display event log. |
| Event Logging | Disabled <u>Enabled</u> | S Enables event logging. |
| System Boot Event | <u>Disabled</u> Enabled | S [Disabled] The event is ignored. [Enabled] The event may be logged. |
| Clear all event logs | | |
| Mark Events as Read | [Enter] | |

Table 1-11 Advanced - Event Logging menu options

1.3 Security Menu

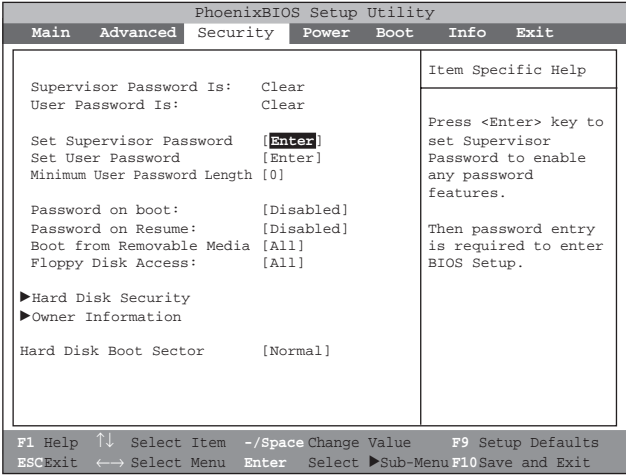

Figure 1-12 Security menu

| Setup Item | Selections | Note (Item Specific Help) |
|------------------------------|----------------------------|---|
| Supervisor Password Is | | Display the setting of Supervisor password. |
| User Password Is | | Display the setting of User password. |
| Set Supervisor Password | | S Supervisor Password controls access to the setup utility. |
| Set User Password | | User password can be set after Supervisor password is set. User Password controls access to the system at boot. |
| Minimum User Password Length | <u>Disabled</u> Enabled | S Sets the user password length. |
| Password on boot | <u>Disabled</u> Enabled | When Password on boot is ' Enabled' , the BIOS requires a password on OS boot. Enables password entry on boot. |
| Password on Resume | <u>Disabled</u> Enabled | Enable this feature to require a password upon Resume from Suspend or Save To Disk Mode. This password is identical to your power-on password. |
| Boot From Removable Media | <u>All</u> Supervisor | This item can be set with Supervisor password security level. When ' Supervisor Only' is selected, removable media is not available with User password security level. Controls boot up from removable media. |

| Setup Item | Selections | Note (Item Specific Help) |
|-----------------------|-------------------------------|---|
| Floppy disk access | <u>All</u> Supervisor Only | This item can be set with Supervisor password security level. When 'Supervisor' only is selected, removable media is not available with User password security level. Control access to floppy drives. |
| Hard disk security | <u>Disabled</u> Enabled | This item can be set with Supervisor password security level. When 'Enabled' is selected, the data of the hard disk are protected with the password lock feature of the drive. You can not read any data on the drive if it is not installed in the same system as it is locked with the password. Enables fixed disk security. |
| Owner Information | | Display owner's information. |
| Hard Disk Boot Sector | Normal Write Protected | Allows boot sector to be written normally or write-protected. |

Table 1-12 Security menu options

1.3.1 Set Supervisor Password

Supervisor Password Is: Clear

```

Set Supervisor Password
-----
Enter New Password [      ]
Confirm New Password [      ]

```

Supervisor Password Is: Set

```

Set Supervisor Password
-----
Enter Current Password [      ]
Enter New Password [      ]
Confirm New Password [      ]

```

1.3.2 Set User Password

User Password Is: Clear

```

Set User Password
-----
Enter New Password [      ]
Confirm New Password [      ]

```

User Password Is: Set

```

Set User Password
-----
Enter Current Password [      ]
Enter New Password [      ]
Confirm New Password [      ]

```

1.4 Power Menu

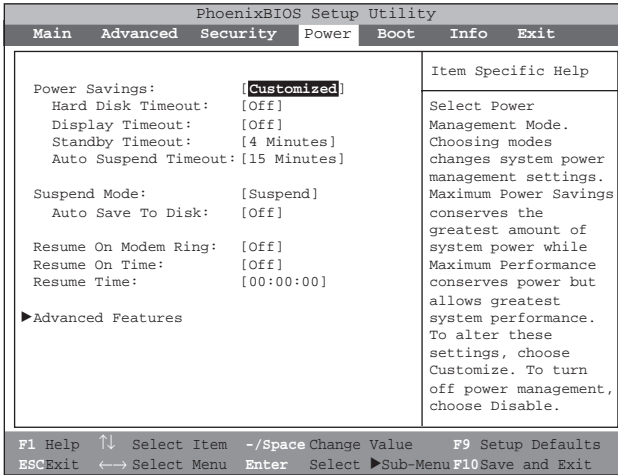

Figure 1-13 Power menu

| Setup Item | Selections | Note (Item Specific Help) |
|-------------------|--|---|
| Power Savings | <ul style="list-style-type: none"> Disabled <u>C</u>ustomized Maximum Power savings Maximum Performance | Select Power Management Mode. Choosing modes changes system power management settings. Maximum Power Savings conserves the greatest amount of system power while Maximum Performance conserves power but allows greatest system performance. To alter these settings, choose Customized. To turn off power management, choose Disabled. |
| Hard Disk Timeout | <ul style="list-style-type: none"> <u>O</u>ff 30 seconds 1 Minute 2 Minutes 4 Minutes 6 Minutes 8 Minutes 10 Minutes 15 Minutes 20 Minutes | Amount of time the hard disk needs to be inactive before it is turned off. |
| Display Timeout | <ul style="list-style-type: none"> <u>O</u>ff 2 Minutes 4 Minutes 6 Minutes 8 Minutes 10 Minutes 15 Minutes 20 Minutes | Amount of time the user input devices need to be inactive before the screen is turned off. |

| Setup Item | Selections | Note (Item Specific Help) |
|----------------------|---|---|
| Standby Timeout | Off 1 Minute 2 Minutes <u>4 Minutes</u> 6 Minutes 8 Minutes 12 Minutes 16 Minutes | Amount of time the system needs to be inactive before entering the Standby Mode. Standby Mode turns off various devices in the system, including the screen, until you start using the computer again. |
| Auto Suspend Timeout | Off 5 Minutes 10 Minutes <u>15 Minutes</u> 20 Minutes 30 Minutes 40 Minutes 60 Minutes | Amount of time the system needs to be inactive before entering the Suspend Mode. |
| Suspend Mode | <u>Suspend</u> Save To Disk | Select the type of Suspend Mode. If you choose Save To Disk the system will save its state to disk and power off. If you choose Suspend the system will save its state but remain in a low power mode. If you choose Suspend then you also have the option of choosing Auto Save To Disk. |
| Auto Save To Disk | <u>Off</u> After 1 Hour | Turn on or off the Auto Save To Disk feature. When Auto Save To Disk is turned on, the system will save its state to disk and then power off after being in Suspend mode for a period of time. |
| Resume On Modem Ring | <u>Off</u> On | Turning this feature on will wake the system up when an incoming call is detected on your modem in Suspend Mode. |
| Resume On Time | <u>Off</u> On | Turning this feature on will wake the system up at 'Resume Time' from Suspend Mode. |
| Resume Time | <u>00:00:00</u> to 23:59:59 | Specify the time when the system is to wake up. <Tab>, <Shift-Tab>, or <Enter> selects field. |
| Advanced Features | | Allows editing of advanced power management features. |

Table 1-13 Power menu options

| Power Saving Mode | Hard Disk | Video | Standby | Auto Suspend |
|-----------------------|------------|-----------|-----------|--------------|
| Disabled | Off | Off | Off | Off |
| Customized | Off | Off | 4 Minutes | 15 Minutes |
| Maximum Power Savings | 30 Seconds | 2 Minutes | 1 Minute | 5 Minutes |
| Maximum Performance | Off | Off | Off | 15 Minutes |

Table 1-13a Preset values for each Power Saving Modes

1.4.1 Power - Advanced Features Modes

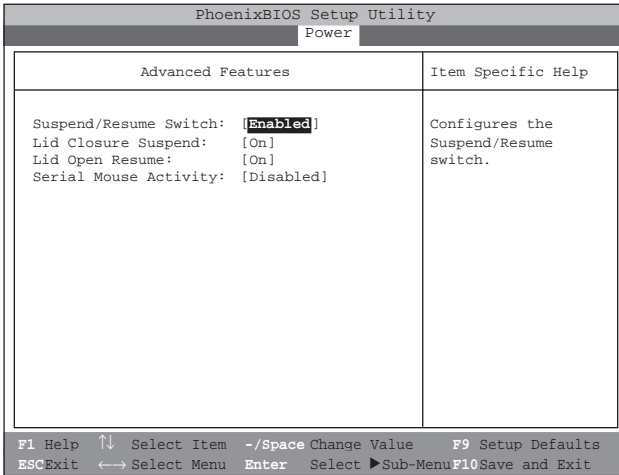

Figure 1-14 Power - Advance Features menu

| Setup Item | Selections | Note (Item Specific Help) |
|-----------------------|----------------------------|---|
| SUS/RES Switch | Disabled <u>Enabled</u> | Set the SUS/RES Switch. |
| Lid Closure Suspend | Off <u>On</u> | Set the Lid Closure Suspend. |
| Lid Open Resume | Off <u>On</u> | Set the Lid Open Resumes. |
| Serial Mouse Activity | <u>Disabled</u> Enabled | Turning this feature on will wake the video up from standby mode when external serial connector activity is detected. |

Table 1-14 Power - Advanced Features menu options

1.5 Boot Menu

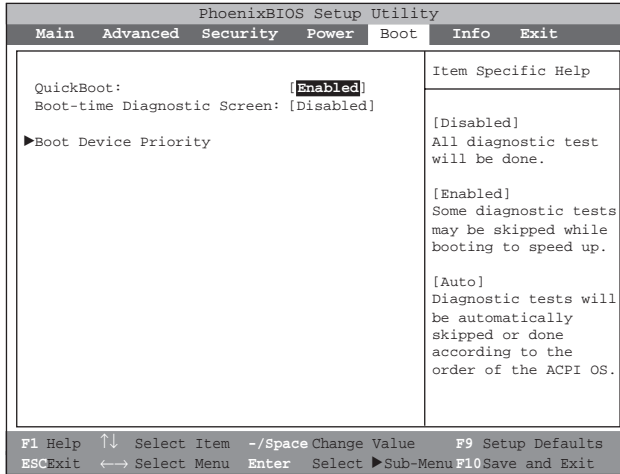

Figure 1-15 Boot menu

| Setup Item | Selections | Note (Item Specific Help) |
|-----------------------------|------------------------------------|---|
| QuickBoot | Disabled <u>Enabled</u> Auto | S Allows the system to skip certain tests while booting. This will decrease the time needed to boot the system. |
| Boot-time Diagnostic Screen | <u>Disabled</u> Enabled | S Display the diagnostic screen during boot. |
| Boot Device Priority | | Select the search order for the types of boot devices. |

Table 1-15 Boot menu options

1.5.1 Boot - Boot Device Priority Menu

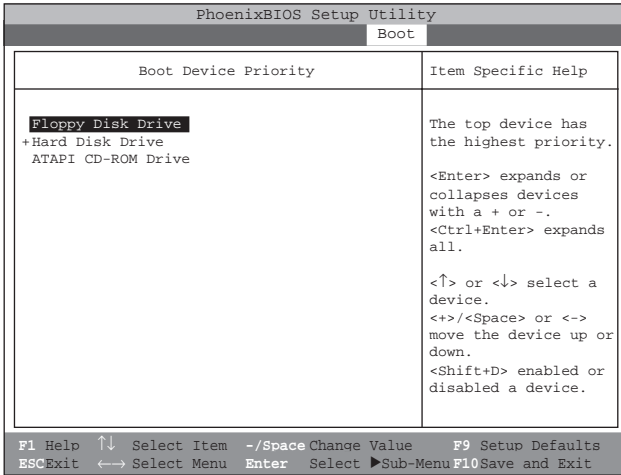

Figure 1-16 Boot - Boot Device Priority menu

Setup Item

Bootable devices available are listed. The following devices will appear depending on the hardware configuration.

- [Diskette Drive]
- [Hard Drive]
- [ATAPI CD-ROM Drive]

Note (Item Specific Help)

<Enter> expands or collapses devices with a + or -.
 <Ctrl+Enter> expands all.
 <↑> or <↓> select a device.
 <+>/<Space> or <-> move the device up or down.
 <Shift+D> enabled or disabled a device.

Table 1-16 Boot - Boot menu DevicePriority options

1.5.1.1 Boot Menu at POST

The following pop up menu will appear when you hit the Esc key during POST. The device list in this pop up menu are same as the list in the Boot Device Priority menu.

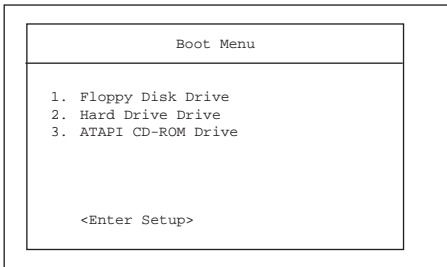

1.6 Info Menu

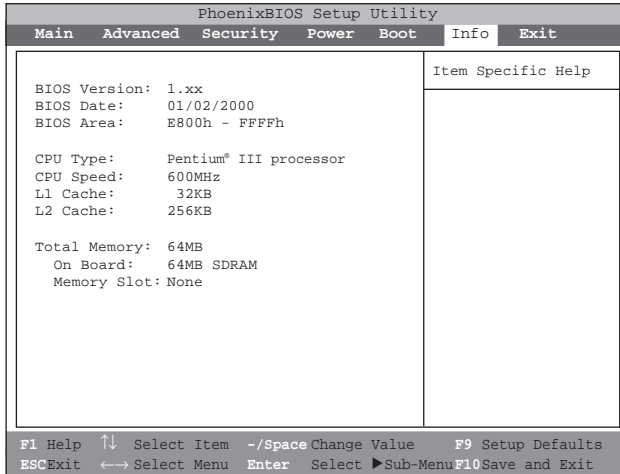

Figure 1-17 Info menu

| Information Item | Values | Note |
|------------------|------------------------|-----------------------------------|
| BIOS Version | n.nn | |
| BIOS Date | MM/DD/YYYY | |
| BIOS Area | xxxxh – FFFFh | This area can not be used as UMB. |
| CPU Type | Pentium® III processor | |
| CPU Speed | 600MHz | |
| L1 Cache | 32 KB | |
| L2 Cache | 256KB | |
| Total Memory | 64 MB to 192 MB | |
| On Board | 64 MB SDRAM | |

Table 1-17 Info menu items

1.7 Exit menu

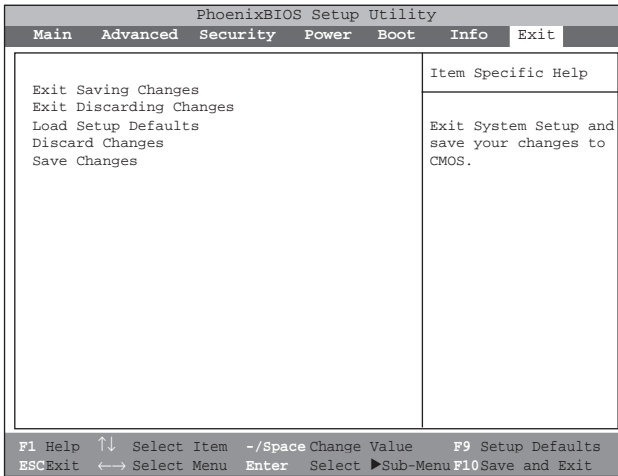

Figure 1-18 Exit menu

| Setup Item | Note (Item Specific Help) |
|-------------------------|---|
| Exit Saving Changes | Exit System Setup and save your changes to CMOS. |
| Exit Discarding Changes | Exit utility without saving Setup data to CMOS. |
| Load Setup Defaults | Load default values for all SETUP items. |
| Discard Changes | Load previous values from CMOS for all SETUP items. |
| Save Changes | Save Setup Data to CMOS. |

Table 1-18 Exit menu options

1.7.1 Exit Saving Changes

| |
|--|
| Setup Confirmation |
| Save configuration changes and exit now? |
| <input type="checkbox"/> Yes <input type="checkbox"/> No |

1.7.4 Discard Changes

| |
|--|
| Setup Confirmation |
| Save configuration changes now? |
| <input type="checkbox"/> Yes <input type="checkbox"/> No |

1.7.2 Exit Discarding Changes

| |
|---|
| Setup Warning |
| Configuration has not been saved! Save before exiting? |
| <input type="checkbox"/> Yes <input type="checkbox"/> No |

1.7.5 Save Changes

| |
|--|
| Setup Confirmation |
| Load default configuration now? |
| <input type="checkbox"/> Yes <input type="checkbox"/> No |

1.7.3 Load Set up Defaults

| |
|--|
| Setup Confirmation |
| Load previous configuration now? |
| <input type="checkbox"/> Yes <input type="checkbox"/> No |

1.8 General Help

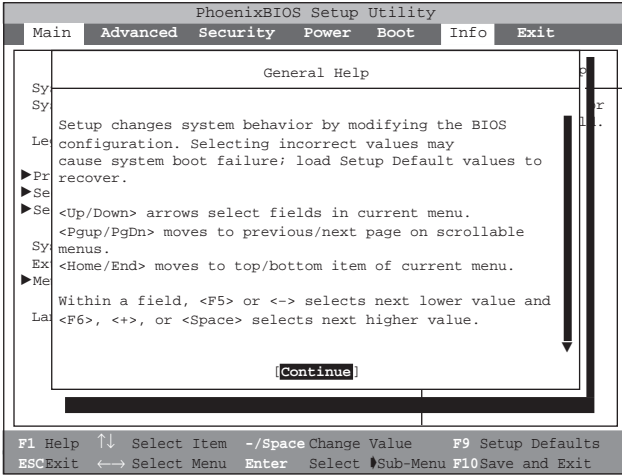

Figure 1-19 General Help

General Help

Setup changes system behavior by modifying the BIOS configuration. Selecting incorrect values may cause system boot failure; load Setup Default values to recover.

<Up/Down> arrows select fields in current menu.
 <PgUp/PgDn> moves to previous/next page on scrollable menus.
 <Home/End> moves to top/bottom item of current menu.

Within a field, <F5> or <-> selects next lower value and <F6>, <+>, or <Space> selects next higher value.

<Left/Right> arrows select menus on menu bar.
 <Enter> displays more options for items marked with _.

<F9> loads factory installed Setup Default values.
 <F10> saves current settings and exits Setup.

<Esc> or <Alt-X> exits Setup; in sub-menus, pressing these keys returns to the previous menu.

<F1> or <Alt-H> displays General Help (this screen).

Table 1-19 Entire Text of General Help

2. POST Diagnostic Screen

```

PhoenixBIOS 4.0 Release 6.0
Copyright 1985-2000 Phoenix Technologies Ltd.
All Rights Reserved

Fujitsu LifeBook BIOS Version 1.xx
Copyright FUJITSU LIMITED 1997-2000.

CPU = XXXXXXXXXXXX processor
0640K System Memory Passed
00XXM Extended Memory Passed
0XXXX Memory Cache Passed
System BIOS Shadowed
Video BIOS Shadowed
Mouse Initialized
Fixed disk 0: xxxxxxxxxxxx
ATAPI CD-ROM: xxxxxxxxxxxx

Press <F2> to enter SETUP

```

Figure 2-1 Typical Diagnostic Screen

Normal Messages

0640K System Memory Passed
 nnnnM Extended Memory Passed
 nnnnK Memory Cache Passed
 System BIOS shadowed
 Video BIOS shadowed
 Mouse initialized
 Press <F2> to enter SETUP
 Entering SETUP ...

Table 2-1 Normal Messages in Diagnostic Screen

Error Messages

System Memory Failed at offset: xxxx
 Failing Bits: zzzz

Extended Memory Failed at offset: xxxx
 Failing Bits: zzzz zzzz

System cache error - Cache disabled

Keyboard controller error

Keyboard error

Diskette drive A error

Failure Fixed Disk n

Error Messages

System timer error

Real time clock error

System CMOS checksum bad - Default configuration used

Previous boot incomplete - Default configuration used

Press <F1> to resume,<F2> to Setup

Check date and time settings

Password locked: Fixed Disk n

No Save To Disk partition or file exists on Fixed Disk
- Save To Disk features is disabled.

Not enough Save To Disk partition or file exists on Fixed
Disk.
- Save To Disk feature is disabled.

Hard Disk Drive is not installed.
- Save To Disk feature is disabled.

Unknown Save To Disk error.
- Save To Disk feature is disabled.

Hard disk sector read function failed.
- Save To Disk feature is disabled.

Hard disk sector write function failed.
- Save To Disk feature is disabled.

Save To Disk partition or file corrupted.
- Save To Disk feature is disabled.

Fixed Disk is not installed. Cannot restore from disk.
To restore from disk : turn off system, install original
fixed disk and reboot.
Press <F1> to continue to boot without save to disk
data.

Fixed Disk has been changed. Cannot restore from disk.
To restore from disk : turn off system, install original fixed
disk and reboot.
Press <F1> to continue to boot without save to disk data.

Table 2-2 Error Messages in Diagnostic Screen

SECTION

4

This section explains what to do when trouble occurs with this computer and when messages are displayed. Read this section as the necessity arises.

1. When This Happens

When you are having trouble with this computer, there is something you think is strange, or there is something you want to do, but do not know how. This section is divided into related items.

● The power does not come on.

| Checkpoint | Cause and Solution |
|--|--|
| Is the AC adaptor connected? | When using this computer for the first time after purchase, the battery is not yet charged, so you must connect the AC adaptor and turn on the main switch. |
| Is the main switch turned on? | If the main switch is not turned on, the power will not come on even if the SUS/RES button is pressed. |
| Is the battery charged? | If a beep is heard when the main switch is turned on, then the battery is running low (LOW BATTERY). Connect the AC adaptor. |
| Has the computer been left unused for a long time? | When using the computer for the first time after leaving it unused for a long time, connect the AC adaptor and switch on the main switch to switch on the power. |

● Nothing displayed on the LCD panel

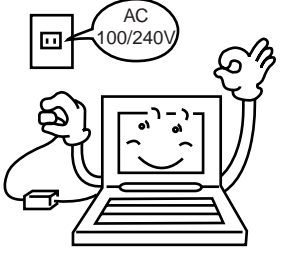
| Checkpoint | Cause and Solution |
|---|---|
| Is  displayed on the LCD panel?  | <ul style="list-style-type: none"> • Displayed Adjust the brightness and darkness with the brightness and contrast controls. • Flashing or not displayed Press the SUS/RES button to put the computer into operating mode. Check if the battery is charged. If it is not charged, connect the AC adaptor and charge it. If you are already using this computer with the AC adaptor connected, check that it is correctly plugged into the power socket and into the computer. |
| Is anything displayed on the status indicator LCD? | Connect the AC adaptor and switch on the main switch. |

| Checkpoint | Cause and Solution |
|---|--|
| Have you been pressing any of the keys? | On this computer, if the power management functions are set and no key is pressed for a certain period of time, the CPU stops and the LCD panel backlight goes out. (In this state, pressing any key lights up the backlight again.) If the computer stops too frequently, change the BIOS setup settings. |
| Is it set to output to the CRT? | Switch over to the LCD display with the [Fn] + [F10] keys. |

● LCD panel hard to read

| Checkpoint | Cause and Solution |
|--------------------------|--|
| Is the control adjusted? | Adjust the brightness with the brightness and contrast controls. |

● Battery is not charged

| Checkpoint | Cause and Solution |
|---|---|
| Is the AC adaptor connected? | Check that the AC adaptor is correctly plugged into the power socket and into the computer. |
| Is the battery overheated (The → on the LCD display flashes.)? | If the ambient temperature is high and the battery temperature becomes too high during use, the battery protection function may be triggered to stop the charging. |
| Is the computer too cold (The → on the LCD display flashes.)? | If the battery temperature falls too low, the battery protection function may be triggered to stop the charging. |
| Was the charging stopped midway? | If you use the computer and disconnect the AC adaptor between the start of charging and the time the → LCD turns off, then the battery will not become fully charged. Once you start charging do not remove the AC adaptor until the → LCD turns off. |

● **The remaining battery charge indicator does not stop flashing.**

| Checkpoint | Cause and Solution |
|-------------------------------------|--|
| Is the battery connected correctly? | Check that the battery is connected correctly. If it is connected correctly, there is an abnormality in the battery pack, so replace the battery pack. |
| Is the battery low? | Attach the AC adaptor and charge the battery. |

● **Floppy disk can not be used.**

| Checkpoint | Cause and Solution |
|---|--|
| If the floppy disk loaded into the floppy disk drive correctly? | Insert the floppy disk with its label facing up, into the drive shutter and keep inserting firmly until you hear a clicking sound. |
| Is the floppy disk formatted? | New floppy disks can not be used until they are formatted (initialized). Format the floppy disk. |
| Is Diskette A set to Not Installed in the BIOS setup? | Check the Diskette A item in the BIOS setup Main menu. |
| Is Diskette access set to Supervisor only in the BIOS setup? | Check the Diskette access item in the BIOS setup Security menu. |
| Is the floppy disk write inhibited? | Set the write protect tab on the floppy disk to the write enable position. |
| Does it work with a different floppy disk? | If it works with a different floppy disk then the problem floppy disk may be damaged. |

● **No sound or minimal sound from speaker**

| Checkpoint | Cause and Solution |
|---|--|
| Is the volume control correctly adjusted? | Turn the volume control for the correct volume. If this does not change the volume, double click the task bar sound indicator and adjust the volume. Check also whether the sound driver is installed correctly. |

● **Can not record from Mic or Line In jack**

| Checkpoint | Cause and Solution |
|--------------------------------|--|
| Is the mic correctly adjusted? | Turn the volume control to obtain the correct volume. If the line jack is connected to the sound source, then check that connection. If this still does not solve the problem, then double click the task bar sound indicator and adjust the volume. |

● **LCD panel does not close.**

| Checkpoint | Cause and Solution |
|---|---|
| Is something caught in the LCD display panel? | Forcing the LCD display panel closed can damage it. Check for something caught in the LCD display panel. Also, a metal object such as a paper clip can cause a breakdown if it gets caught in between the keys. |

● **The power management function is not executed.**

| Checkpoint | Cause and Solution |
|---|---|
| Is Power Savings set to off in the BIOS setup? | Reset the BIOS setup. |
| Are you executing a program that rewrites the screen? | If you are executing a program that rewrites the screen even when no key is pressed, for example a clock display or screen save, the power management function is not executed. |

● **Message displayed on screen**

See the message list.

● **Data cannot be read from the CD-ROM drive.**

| Checkpoint | Cause and Solution |
|---|--|
| Is the CD-ROM correctly set? | Set the CD-ROM correctly with its label facing upwards. |
| Is there any dirt, condensation or water on the CD-ROM? | Wipe it from the center outwards with a dry, soft cloth. |
| Is the CD-ROM scratched or extremely warped? | Replace the CD-ROM. |
| Are you using a non-standard CD-ROM? | Use a CD-ROM which conforms to the standards. |

● **The CD cannot be ejected from the CD-ROM.**

| Checkpoint | Cause and Solution |
|--------------------------|---|
| Is it in operating mode? | The CD can only be ejected when the personal computer main unit is in operating mode because its CD-ROM drive has an electronic lock. Check that the personal computer main unit is in operating mode and press the EJECT button. If for some reason the CD tray does not come out even when you press the EJECT button, insert a clip or something into the hole to the right of the EJECT button and pull the tray out. If the tray doesn't still come out, click the CD-ROM icon in the "My Computer" window with the right button of the mouse and then click "EJECT". |

2. Care and Maintenance

If you use your Fujitsu LifeBook notebook carefully, you will increase its life and reliability. This section provides some tips for looking after the notebook and its devices.

Caution:

Electrical equipment may be hazardous if misused. Operations of this product or similar products, must always be supervised by an adult. Do not allow children access to the interior of any electrical products and do not permit them to handle any cables.

LIFEBOOK NOTEBOOK

Caring for your LifeBook Notebook

- Your Lifebook notebook is a durable but sensitive electronic device. Treat it with care.
- Make a habit of transporting it in a suitable carrying case.
- Do not attempt to service the computer yourself. Always follow installation instructions closely.
- Keep it away from food and beverages.
- If you accidentally spill liquid on your notebook:
 1. Turn it off.
 2. Position it so that the liquid can run out.
 3. Let it dry out for 24 hours, or longer if needed.
 4. If your notebook will not boot after it has dried out, call your support representative.
- Do not use your LifeBook notebook in a wet environment (near a bathtub, swimming pool).
- Always use the AC adapter and batteries that are approved for your notebook.
- Avoid exposure to sand, dust and other environmental hazards.
- Do not expose your LifeBook notebook to direct sunlight for long periods of time as temperatures above 140°F (60°C) may damage your notebook.
- Keep the covers closed on the connectors and slots when they are not in use.
- Do not put heavy or sharp objects on the computer.
- If you are carrying your LifeBook notebook in a briefcase, or any other carrying case, make sure that there are no objects in the case pressing on the lid.
- Do not drop your LifeBook notebook.
- Do not touch the screen with any sharp objects.

Cleaning your LifeBook Notebook

- Always disconnect the power plug. (Pull the plug, not the cord.)
- Clean your LifeBook notebook with a damp, lint-free cloth. Do not use abrasives or solvents.
- Use a soft cloth to remove dust from the screen. Never use glass cleaners.

Storing your LifeBook Notebook

- If storing your notebook for a month or longer, turn your LifeBook notebook off and remove all Lithium Ion batteries.
- Store your LifeBook notebook and batteries separately. If you store your notebook with a battery installed, the battery will discharge, and battery life will be reduced. In addition, a faulty battery might damage your notebook.
- Store your LifeBook notebook in a cool, dry location. Temperatures should remain between - 25°C (13°F) and 60°C (140°F).

Travelling with your LifeBook Notebook

- Do not transport your LifeBook notebook while it is turned on.
- Do not check your LifeBook notebook as baggage. Carry it with you.
- Always bring your System Recovery CD that came with your LifeBook notebook when you travel. If you experience system software problems while travelling you may need it to correct any problems.
- Never put your LifeBook notebook through a metal detector. Have your notebook hand-inspected by security personnel. You can, however, put your LifeBook notebook through a properly tuned X-ray machine. To avoid problems, place your notebook close to the entrance of the machine and remove it as soon as possible or have your notebook hand-inspected by security personnel. Security officials may require you to turn your notebook On. Make sure you have a charged battery on hand.

| Outlet type | Location |
|---|---|
|  | United States, Canada, parts of Latin America, Japan, Korea, the Philippines, Taiwan |
|  | Russia and the Commonwealth of Independent States (CIS), most of Europe, parts of Latin America, the Middle East, parts of Africa, Hong Kong, India, most of South Asia |
|  | Mexico, United Kingdom, Ireland, Malaysia, Singapore, parts of Africa |
|  | China, Australia, New Zealand |

- When travelling with the hard drive removed, wrap the drive in a non-conducting materials (cloth or paper). If you have the drive checked by hand, be ready to install the drive if needed. Never put your hard drive through a metal detector. Have your hard drive hand-inspected by security personnel. You can however, put your hard drive through a properly tuned X-ray machine.
- Take the necessary plug adapters if you're travelling overseas. Check the following diagram to determine which plug adapter you'll need or ask your travel agent.

BATTERIES

Caring for your Batteries

- Always handle batteries carefully.
- Do not short-circuit the battery terminals (that is, do not touch both terminals with a metal object). Do not carry loose batteries in a pocket or purse where they may mix with coins, keys, or other metal objects. Doing so may cause an explosion or fire.
- Do not drop, puncture, disassemble, mutilate or incinerate the battery.
- Recharge batteries only as described in this manual and only in ventilated areas.
- Do not leave batteries in hot locations for more than a day or two. Intense heat can shorten battery life.
- Do not leave a battery in storage for longer than 6 months without recharging it.

Increasing Battery Life

- Power your LifeBook notebook through the AC or optional auto/airline adapter whenever possible.
- If your LifeBook notebook is running on battery power all day, connect it to the AC adapter overnight to recharge the battery.
- Keep brightness to the lowest level comfortable.
- Set the power management for maximum battery life.
- Put your LifeBook notebook in Suspend mode when it is turned on and you are not actually using it.
- Limit your DVD/CD-RW/CD-ROM access.
- Disable the Windows CD automatic insertion function.
- Always use fully charged batteries.
- Eject PCMCIA cards when not in use.

FLOPPY DISKS AND DRIVES

Caring for your Floppy Disks

- Avoid using the floppy disks in damp and dusty locations.
- Never store a floppy disk near a magnet or magnetic field.
- Do not use a pencil or an eraser on a disk or disk label.
- Avoid storing the floppy disks in extremely hot or cold locations, or in locations subject to severe temperature changes. Store at temperatures between 50°F (10°C) and 125°F (52°C)
- Do not touch the exposed part of the disk behind the metal shutter.

Caring for your Floppy Disk Drive

- To clean, wipe the floppy disk drive clean with a dry soft cloth, or with a soft cloth dampened with water or a solution of neutral detergent. Never use benzene, paint thinner or other volatile material.
- Avoid storing the floppy disk drive in extremely hot or cold locations, or in locations subject to severe temperature changes. Store at temperatures between 50°F (10°C) and 125°F (52°C)
- Keep the floppy disk drive out of direct sunlight and away from heating equipment.
- Avoid storing the floppy disk drive in locations subject to shock and vibration.
- Never use the floppy disk drive with any liquid, metal, or other foreign matter inside the floppy disk drive or disk.
- Never disassemble or dismantle your floppy disk drive.

DVD/CD-RW/CDs

Caring for your DVD/CD-RW/CDs

- DVD/CD-RW/CDs are precision devices and will function reliably if given reasonable care.
- Always store your DVD/CD-RW/CDs in its case when it is not in use.
- Always handle DVD/CD-RW/CDs by the edges and avoid touching the surface.
- Avoid storing any DVD/CD-RW/CDs in extreme temperatures.
- Do not bend DVD/CD-RW/CDs or set heavy objects on them.
- Do not spill liquids on DVD/CD-RW/CDs.
- Do not scratch DVD/CD-RW/CDs.
- Do not put a label on DVD/CD-RW/CDs.
- Do not get dust on DVD/CD-RW/CDs.
- Never write on the label surface with a ballpoint pen or pencil. Always use a felt pen.
- If a DVD/CD-RW/CD is subjected to a sudden change in temperature, cold to warm condensation may form on the surface. Wipe the moisture off with a clean, soft, lint free cloth and let it dry at room temperature, DO NOT use a hair dryer or heater to dry DVD/CD-RW/CDs.
- If a DVD/CD-RW/CD is dirty, use only a DVD/CD-RW/CD cleaner or wipe it with a clean, soft, lint free cloth starting from the inner edge and wiping to the outer edge.

Caring for your DVD/CD-RW/CD-ROM Drive

Your DVD/CD-RW/CD-ROM drive is durable but you must treat it with care. Please pay attention to the following points:

- The drive rotates the compact disk at a very high speed. Do not carry it around or subject it to shock or vibration with the power on.
- Avoid using or storing the drive where it will be exposed to extreme temperatures.
- Avoid using or storing the drive where it is damp or dusty.
- Avoid using or storing the drive near magnets or devices that generate strong magnetic fields.
- Avoid using or storing the drive where it will be subjected to shock or vibration.
- Do not disassemble or dismantle the DVD/CD-RW/D-ROM drive.

PC CARDS

Caring for your PC Cards

PC Cards are durable, but you must treat them with care. The documentation supplied with your PC Card will provide specific information, but you should pay attention to the following points:

- To keep out dust and dirt, store PC Cards in their protective sleeves when they are not installed in your notebook.
- Avoid prolonged exposure to direct sunlight or excessive heat.
- Keep the cards dry.
- Do not flex or bend the cards, and do not place heavy objects on top of them.
- Do not force cards into the slot.
- Avoid dropping cards, or subjecting them to excessive vibration.

3. Glossary

AC Adapter

A device which converts the AC voltage from a wall outlet to the DC voltage needed to power your notebook.

Active-Matrix Display

A type of technology for making flat-panel displays which has a transistor or similar device for every pixel on the screen.

APM

Advanced Power Management.

Auto/Airline Adapter

A device which converts the DC voltage from an automobile cigarette lighter or aircraft DC power outlet to the DC voltage needed to power your notebook.

BIOS

Basic Input-Output System. A program and set of default parameters stored in ROM which tests and operates your notebook when you turn it on until it loads your installed operating system from disk. Information from the BIOS is transferred to the installed operating system to provide it with information on the configuration and status of the hardware.

Bit

An abbreviation for binary digit. A single piece of information which is either a one (1) or a zero (0).

bps

An abbreviation for bits per second. Used to describe data transfer rates.

Boot

To start-up a computer and load its operating system from disk, ROM or other storage media into RAM.

Bus

An electrical circuit which passes data between the CPU and the sub-assemblies inside your notebook.

Byte

8 bits of parallel binary information.

Cache Memory

A block of memory built into the micro-processor which is much faster to access than your system RAM and used in specially structured ways to make your overall data handling time faster.

CardBus

A faster, 32-bit version of the PC Card interface which offers performance similar to the 32-bit PCI architecture.

CD-ROM

Compact disc read only memory. This is a form of digital data storage which is read optically with a laser rather than a magnetic head. A typical CD-ROM can contain about 600MB of data and is not subject to be crashing into the surface and destroying the data when there is a failure nor to wear from reading.

CMOS RAM

Complementary metal oxide semiconductor random access memory. This is a technology for manufacturing random access memory which requires very low level power to operate.

COMM Port

Abbreviation for communication port. This is your serial interface connection.

Command

An instruction which you give your operating system. Example: run a particular application or format a floppy disk.

Configuration

The combination of hardware and software that make up your system and how it is allocated for use.

CRT

Cathode Ray Tube. A display device which uses a beam of electronic particles striking a luminescent screen. It produces a visual image by varying the position and intensity of the beam.

Data

The information a system stores and processes.

DC

Direct current. A voltage or current that does not fluctuate periodically with time.

Default Value

A pre programmed value to be used if you fail to set your own.

DIMM

Dual-in-line memory module.

LAN

Local Area Network. An interconnection of computers and peripherals within a single limited geographic location which can pass programs and data amongst themselves.

LCD

Liquid Crystal Display. A type of display which makes images by controlling the orientation of crystals in a crystalline liquid.

Lithium ion Battery

A type of rechargeable battery which has a high power-time life for its size and is not subject to the memory effect as Nickel Cadmium batteries.

LPT Port

Line Printer Port. A way of referring to parallel interface ports because historically line printers were the first and latter the most common device connected to parallel ports.

MB

Megabyte.

Megahertz

1,000,000 cycles per second.

Memory

A repository for data and applications which is readily accessible to your notebook CPU.

MHz

Megahertz.

MIDI

Musical Instrument Digital Interface. A standard communication protocol for exchange of information between computers and sound producers such as synthesizers.

Modem

A contraction for MODulator-DEModulator. The equipment which connects a computer or other data terminal to a communication line.

Monaural

A system using one channel to process sound from all sources.

MPU-401

A standard for MIDI interfaces and connectors.

NTSC

National TV Standards Commission. The standard for TV broadcast and reception for the USA.

Operating System

A group of control programs that convert application commands, including driver programs, into the exact form required by a specific brand and model of microprocessor in order to produce the desired results from that particular equipment.

Parallel Port

A connection to another device through which data is transferred as a block of bits simultaneously with a wire for each bit in the block and with other wires only for control of the device not for transfer of data.

Partition

A block of space on a hard drive which is set aside and made to appear to the operating system as if it were a separate disk, and addressed by the operating system accordingly.

PCMCIA

PCMCIA is trademark of the Personal Computer Memory Card International Association. The Personal Computer Memory Card International Association is an organization that sets standards for add-in cards for personal computers.

Peripheral Device

A piece of equipment which performs a specific function associated with but not integral to a computer. Examples: a printer, a mode, a CD-ROM.

Pitch (keyboard)

The distance between the centers of the letter keys of a keyboard.

Pixel

The smallest element of a display, a dot of color on your display screen. The more pixels screen. The more pixels per area the clearer your image will appear.

POST

Power On Self Test. A program which part of the BIOS which checks the configuration and operating condition of your hardware whenever power is applied to your notebook. Status and error messages may be displayed before the operating system is loaded. If the self test detects failures that are so serious that operation can not continue, the operating system will not be loaded.

Disk

A spinning platter of magnetic data storage media. If the platter is very stiff it is a hard drive, if it is highly flexible it is a floppy disk, if it is a floppy disk in a hard housing with a shutter it is commonly called diskette.

Disk Drive

The hardware which spins the disk and has the heads and control circuitry for reading and writing the data on the disk.

Diskette

A floppy disk in a hard housing with a shutter.

DMA

Direct Memory Access. Special circuitry for memory to memory transfer of data which do not require CPU action.

DMI

Desktop Management Interface. A standard that provides PC management applications with a common method of locally or remotely querying and configuring PC computer systems hardware and software components, and peripherals.

DOS

Disk Operating System (MS-DOS is a Microsoft Disk Operating System).

Driver

A computer program which converts application and operating system commands to external devices into the exact form required by a specific brand and model of device in order to produce the desired results from that particular equipment.

ECP

Extended Capability Port. A set of standards for high speed data communication and interconnection between electronic devices.

ESD

Electro-Static Discharge. The sudden discharge of electricity from a static charge which has built-up slowly. Example: the shock you get from a doorknob on a dry day or the sparks you get from brushing hair on a dry day.

Extended Memory

All memory more than the 640KB recognized by MS-DOS as system memory.

FCC

Federal Communication Commission.

Floppy Disk

A spinning platter of magnetic data storage media which is highly flexible.

GB

Gigabyte.

Hard drive

A spinning platter of magnetic data storage media where the platter is very stiff.

Hexadecimal

A decimal notation for the value of a 4 bit binary number. (0-9, A, B, C, D, E, F) Example: 2F in hexadecimal = 00101111 = 47 in decimal.

I/O

Input/Output. Data entering and leaving your notebook in electronic form.

I/O Port

The connector and associated control circuits for data entering and leaving your notebook in electronic form.

IDE

Intelligent Drive Electronics. A type of control interface for a hard drive which is inside the hard drive unit.

Infrared

Light just beyond the red portion of the visible light spectrum which is invisible to humans.

IR

An abbreviation for infrared.

IrDA

Infrared Data Association. An organization which produces standards for communication using infrared as the carrier.

IRQ

Interrupt Request. An acronym for the hardware signal to the CPU that an external event has occurred which needs to be processed.

KB

Kilobyte.

Program

An integrated set of coded commands to your computers telling your hardware what to do and how and when to do it.

PS/2

An IBM series of personal computers which established a number of standards for connecting external devices such as keyboards and monitors.

RAM

Random Access Memory. A hardware component of your notebook that holds binary information (both program and data) as long as it has the proper power applied to it.

RAM Module

A printed circuit card with memory and associated circuitry which allows the user to add additional memory to the computer without special tools.

Reset

The act of reloading the operating system. A reset erases all information stored in RAM.

Restart

See Reset.

Resume

To proceed after interruption. In your notebook this refers to returning to active operation after having been in one of the suspension states.

ROM

Read Only Memory. A form of memory in which information is stored by physically altering the material. Data stored in this way can not be changed by your notebook and does not require power to maintain it.

SDRAM

Synchronous Dynamic Random Access Memory.

Serial Port

A connection to another device through which data is transferred one bit at a time on a single wire with any other wires only for control of the device not for transfer of data.

Shadow RAM

A technique of copying data or applications stored in ROM (Read Only Memory) into RAM (Random Access Memory) for access during actual operation. RAM is much faster to access than ROM, however ROM contents are not lost when power is removed. Shadowing allows permanently stored information to be rapidly accessed.

SMART

Self-Monitoring, Analysis and Reporting Technology (SMART) is an emerging technology that provides near-term failure predictions for hard drives. When SMART is enabled the hard drive monitors predetermined drive attributes that are susceptible to degradation over time. If a failure is likely to occur, SMART makes a status report available so that the LifeBook can prompt the user to back up the data on the drive. Naturally not all failures are predictable. SMART predictability is limited to those attributes which the drive can self-monitor. In those cases where SMART can give advance warning, a considerable amount of precious data can be saved.

SRAM

Static random access memory. A specific technology of making RAM which does not require periodic data refreshing.

Status Indicator

A display which reports the condition of some portion of your hardware. On your notebook this is an LCD screen just above the keyboard.

Stereo (audio)

A system using two channels to process sound from two different sources.

Stroke (keyboard)

The amount of travel of a key when it is pressed from resting to fully depressed.

Suspend

To make inoperative for a period of time. Your notebook uses various suspension states to reduce power consumption and prolong the charge of your battery.

SVGA

Super VGA.

S-Video

Super Video. A component video system for driving a TV or computer monitor.

System Clock

An oscillator of fixed precise frequency which synchronizes the operation of the system and is counted to provide time of day and date.

TFT

Thin Film Transistor - A technology for flat display panels which uses a thin film matrix of transistors to control each pixel of the display screen individually.

UL

Underwriters Laboratories - An independent organization that tests and certifies the electrical safety of devices.

VGA

Video Graphics Array. A video display standard originally introduced by IBM with the PS/2 series of personal computers.

VRAM

Video Random Access Memory. A memory dedicated to video display data and control.

WFM

Wired for Management is Intel's broad-based initiative to reduce the total cost of ownership (TCO) of business computing without sacrificing power and flexibility.

Write Protect

Prevent alteration of the binary state of all bits in a storage media. Example: all information on a device such as a floppy diskette; a block of space in a storage media such as partition of a hard drive; a file or directory of floppy diskette or hard drive.

XGA

Extended VGA.

Zip Drive

A 100MB read/write removable media disk drive.

Zoomed Video

A PC Card port which allows notebook PCs to deliver full screen broadcast quality video through third party PC Cards, including TV tuners, video capture, and MPEG full-motion video.

Fujitsu PC (Asia) Pte Ltd
200 Pandan Loop
#05-03 Pantech 21
The Computer Centre
Singapore 128388
Tel: 65-776 0688
Fax: 65-776 0788

Fujitsu PC (Asia) Pte Ltd
(Malaysia Branch)
8th Floor Wisma Damansara
Jalan Semantan
50490 Kuala Lumpur
Malaysia
Tel: 603-253 3997
Fax: 603-253 4245

Website : www.fujitsu-pc-asia.com